

# eCPRI Specification V1.2 (2018-06-25)

---

*Interface Specification*

## **Common Public Radio Interface: eCPRI Interface Specification**

---

The eCPRI specification has been developed by Ericsson AB, Huawei Technologies Co. Ltd, NEC Corporation and Nokia (the "Parties") and may be updated from time to time. Further information about eCPRI, and the latest specification, may be found at <http://www.cpri.info>

BY USING THE eCPRI SPECIFICATION, YOU ACCEPT THE "Interface Specification Download Terms and Conditions" FOUND AT <http://www.cpri.info/spec.html>

IN ORDER TO AVOID ANY DOUBT, BY DOWNLOADING AND/OR USING THE ECPRI SPECIFICATION NO EXPRESS OR IMPLIED LICENSE AND/OR ANY OTHER RIGHTS WHATSOEVER ARE GRANTED FROM ANYBODY.

© 2018 Ericsson AB, Huawei Technologies Co. Ltd, NEC Corporation and Nokia.

---

1	<b>Table of Contents</b>	
2	<b>1. Introduction.....</b>	<b>4</b>
3	<b>2. System Description .....</b>	<b>5</b>
4	<b>2.1. Definitions/Nomenclature .....</b>	<b>5</b>
5	<b>2.2. System Architecture .....</b>	<b>6</b>
6	<b>2.3. Functional Description .....</b>	<b>7</b>
7	2.3.1. Functional Decomposition .....	8
8	<b>3. Interface Specification.....</b>	<b>10</b>
9	<b>3.1. Protocol Overview.....</b>	<b>10</b>
10	3.1.1. Physical Layer .....	12
11	<b>3.2. User Plane .....</b>	<b>12</b>
12	3.2.1. User Plane over Ethernet .....	12
13	3.2.2. User Plane over IP .....	13
14	3.2.3. eCPRI Message Format .....	13
15	3.2.3.1. eCPRI Transmission Byte Order .....	14
16	3.2.3.2. Common Header .....	14
17	3.2.3.3. eCPRI Payload .....	15
18	3.2.3.4. Mapping Examples .....	15
19	3.2.4. Message Types .....	16
20	3.2.4.1. Message Type #0: IQ Data .....	16
21	3.2.4.2. Message Type #1: Bit Sequence .....	18
22	3.2.4.3. Message Type #2: Real-Time Control Data .....	20
23	3.2.4.4. Message Type #3: Generic Data Transfer .....	21
24	3.2.4.5. Message Type #4: Remote Memory Access .....	23
25	3.2.4.6. Message Type #5: One-Way Delay Measurement....	27
26	3.2.4.7. Message Type #6: Remote Reset.....	33
27	3.2.4.8. Message Type #7: Event Indication .....	35
28	3.2.4.9. Message Type #8-#63: Reserved .....	40
29	3.2.4.10. Message Type #64-#255: Vendor Specific.....	40
30	<b>3.3. C&amp;M Plane .....</b>	<b>41</b>
31	<b>3.4. Synchronization Plane.....</b>	<b>41</b>
32	<b>3.5. QoS .....</b>	<b>41</b>
33	3.5.1. VLAN Tagging for Ethernet-switched fronthaul networks.....	41
34	3.5.2. QoS for IP-routed fronthaul networks .....	41
35	<b>4. Forward and Backward Compatibility .....</b>	<b>42</b>
36	<b>4.1. Fixing eCPRI Protocol Revision Position .....</b>	<b>42</b>
37	<b>4.2. Reserved Bits and Value Ranges within eCPRI .....</b>	<b>42</b>
38	<b>4.3. eCPRI specification release version .....</b>	<b>42</b>
39	<b>4.4. Specification release version mapping to eCPRI protocol revision .....</b>	<b>42</b>
40	<b>5. Compliance .....</b>	<b>43</b>
41	<b>6. Annex A - Supplementary Specification Details (Informative) .....</b>	<b>44</b>
42	<b>6.1. Functional Decomposition .....</b>	<b>44</b>
43	6.1.1. eCPRI Functional Decomposition .....	44
44	6.1.2. Bit Rate Calculations / Estimations .....	46
45	6.1.2.1. Bit Rate Calculation Example.....	46
46	<b>6.2. Synchronization and Timing .....</b>	<b>47</b>
47	6.2.1. Synchronization of eRE .....	47
48	6.2.2. Synchronization of eREC.....	47
49	<b>6.3. Link Delay Management .....</b>	<b>47</b>
50	6.3.1. Reference Points for Delay Measurement .....	48
51	6.3.2. Delay Management example .....	52
52	<b>6.4. Network Connection Maintenance.....</b>	<b>54</b>

1	<b>6.5. Networking .....</b>	<b>55</b>
2	6.5.1. Difference between eCPRI and CPRI .....	55
3	<b>6.6. Priority considerations .....</b>	<b>56</b>
4	<b>6.7. Message Ordering Considerations .....</b>	<b>56</b>
5	<b>6.8. Security.....</b>	<b>57</b>
6	6.8.1. eCPRI Network Security Protocol .....	57
7	6.8.2. eCPRI Network Security Specification .....	57
8	6.8.2.1. User plane .....	57
9	6.8.2.2. C&M plane.....	57
10	6.8.2.3. Synchronization plane.....	57
11	<b>7. List of Abbreviations .....</b>	<b>58</b>
12	<b>8. References .....</b>	<b>61</b>
13	<b>9. History .....</b>	<b>62</b>
14		

# 1. Introduction

The Common Public Radio Interface (CPRI) is an industry cooperation aimed at defining publicly available specifications for the key internal interface of radio base stations, such as eCPRI connecting the eCPRI Radio Equipment Control (eREC) and the eCPRI Radio Equipment (eRE) via a so-called fronthaul transport network. The parties cooperating to define the specification are Ericsson AB, Huawei Technologies Co. Ltd, NEC Corporation and Nokia.

## Motivation for eCPRI:

Compared to CPRI [1], eCPRI makes it possible to decrease the data rate demands between eREC and eRE via a flexible functional decomposition while limiting the complexity of the eRE.

## Scope of Specification:

The necessary items for transport, connectivity and control are included in the specification. This includes User Plane data, Control and Management Plane transport mechanisms, and means for synchronization.

The eCPRI specification supports 5G and enables increased efficiency in order to meet the needs foreseen for 5G Mobile Networks. In contrast to CPRI, the eCPRI specification supports more flexibility in the positioning of the functional split inside the Physical Layer of the cellular base station.

The scope of the eCPRI specification is to enable efficient and flexible radio data transmission via a packet based fronthaul transport network like IP or Ethernet. eCPRI defines a protocol layer which provides various - mainly User Plane data specific - services to the upper layers of the protocol stack.

The specification has the following scope (see Figure 1):

1. The internal radio base station interface establishing a connection between 'eCPRI Radio Equipment Control' (eREC) and 'eCPRI Radio Equipment' (eRE) via a packet based transport network is specified.
2. Three different information flows (eCPRI User Plane data, C&M Plane data, and Synchronization Plane data) are transported over the interface.
3. The specification defines a new eCPRI Layer above the Transport Network Layer. Existing standards are used for the transport network layer, C&M and Synchronization.

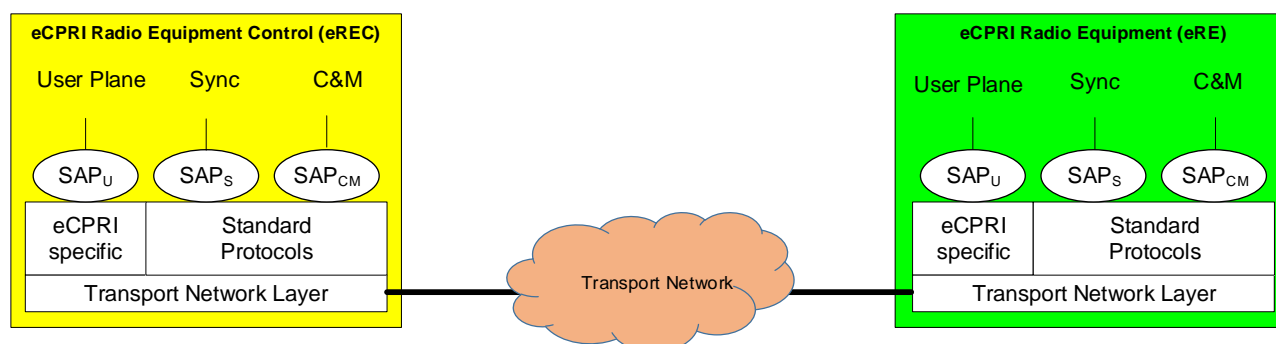

Figure 1: System and Interface Definition

The eCPRI interface can also be used between two eRECs or between two eREs.

---

## 2. System Description

This section describes the eCPRI related parts of the basic radio base station system architecture and defines the mapping of the functions to the different nodes. Furthermore, the reference configurations and the basic nomenclature used in the following sections are defined.

The following description is based on the Evolved UMTS Terrestrial Radio Access (E-UTRA) and 5G. However, the interface may also be used for other radio standards.

### 2.1. Definitions/Nomenclature

This section provides the basic nomenclature that is used in the following sections.

#### **eCPRI node:**

The radio base station system is composed of two basic eCPRI nodes, the eCPRI Radio Equipment Control and the eCPRI Radio Equipment (see Figure 1). The eCPRI Radio Equipment Control and the eCPRI Radio Equipment are described in the following chapter. The radio base station system shall contain at least two eCPRI nodes, at least one of each type: eREC and eRE.

#### **eREC / eRE element:**

A hardware or software component within an eCPRI node which alone does not constitute a full eCPRI node.

#### **Protocol planes:**

The following planes are outlined:

C&M Plane: Control and Management data flow for the operation, administration and maintenance of the nodes.

User Plane: Three data flows covered by the User Plane:

a) Data flow to be transferred from the radio base station to the User Equipment (UE) and vice versa.

b) Real time control data related to a).

c) Other eCPRI flows not covered by other protocol planes/flows.

Synchronization Plane: Data flow for synchronization and timing information between nodes.

#### **eCPRI Protocol Layer:**

A Protocol Layer defined by this specification and providing specific services to the upper layers.

#### **Service Access Points:**

For all protocol planes except Connection OAM, service access points are defined. These service access points are denoted as  $SAP_{CM}$ ,  $SAP_S$  and  $SAP_U$  as illustrated in Figure 1. A service access point is defined on a per logical connection basis.

#### **Logical connection:**

A "logical connection" defines the interconnection between SAPs (e.g.,  $SAP_U$ ) across peered eCPRI nodes.

#### **Grandmaster Clock (GM):**

Reference clock of a Precision Time Protocol-based Transport network. The GM can be located in the network as well as in the eREC or eRE.

#### **Downlink:**

Direction from eNB/gNB to UE.

#### **Uplink:**

Direction from UE to eNB/gNB.

1 **Service:**

2 Method to access one or more functionalities via the eCPRI protocol. This method typically involves the  
3 transmission/reception of eCPRI messages.

4 Figure 2 illustrates basic definitions related to service access points.

5

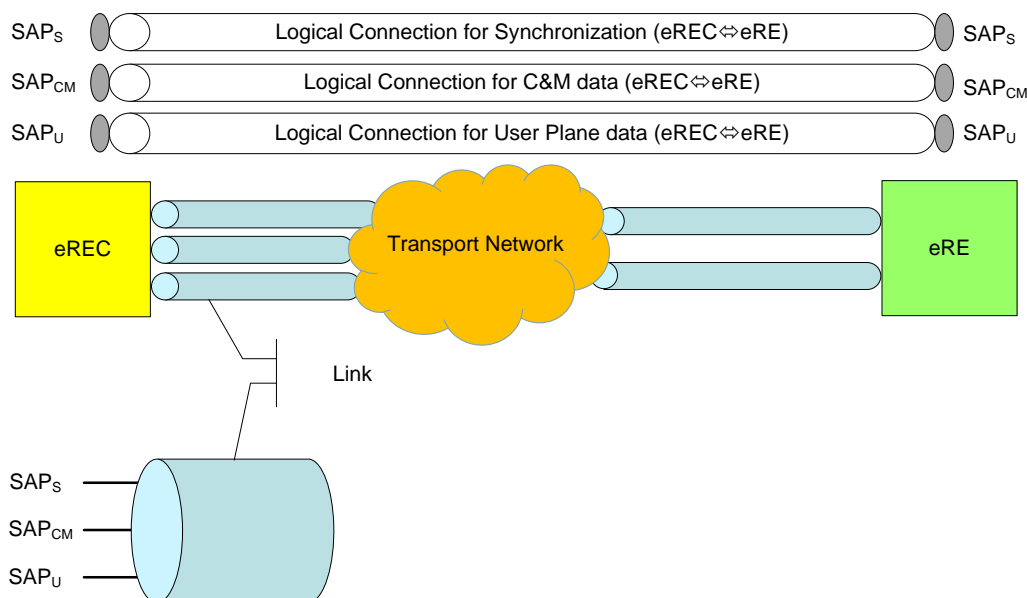

6

7

Figure 2: Illustration of basic definitions

8

## 9 2.2. System Architecture

10 Radio base stations should offer deployment flexibility to mobile network operators, i.e., in addition to an all-  
11 in-one radio base station, more flexible radio base station system architectures involving remote radio  
12 equipment shall be supported. This may be achieved by a decomposition of the radio base station into two  
13 basic building blocks, the so-called eCPRI Radio Equipment Control (eREC) and the eCPRI Radio  
14 Equipment (eRE). Both parts may be physically separated (i.e., the eRE may be close to the antenna,  
15 whereas the eREC is generally located in a conveniently accessible site) and connected via a transport  
16 network.

17 Typically, the eREC contains part of the PHY layer functions and higher layer functions of the air interface,  
18 whereas the eRE contains the other part of the PHY layer functions and the analog radio frequency  
19 functions. The basic idea of the functional split between both parts is described in section 2.3.1. Several  
20 examples of functional splits are described in informative Annex 6.1.

21 User Plane data (i.e. information flows between split PHY layer functions in eREC and eRE and their real-  
22 time control), control and management and synchronization signals are packetized, multiplexed and  
23 transferred over the transport network (fronthaul network) which eREC(s) and eRE(s) are connected to.

24 eCPRI does not constrain the use of network-layer and data link-layer protocols to form the network, so any  
25 type of network can be used for eCPRI provided eCPRI requirements (defined in [15]) are fulfilled. eCPRI  
26 also uses existing de-facto/de-jure standard protocols as much as possible where available. The basic idea  
27 is illustrated in Figure 1.

28 Figure 3 shows an example of a system architecture with local eCPRI. eCPRI is used as an internal interface  
29 within the eREC and/or eRE (local eCPRI) when the eREC/eRE consists of multiple eREC/eRE elements. In  
30 addition, eCPRI and CPRI can coexist in a system. Please note that eCPRI has no backward compatibility  
31 with legacy CPRI.

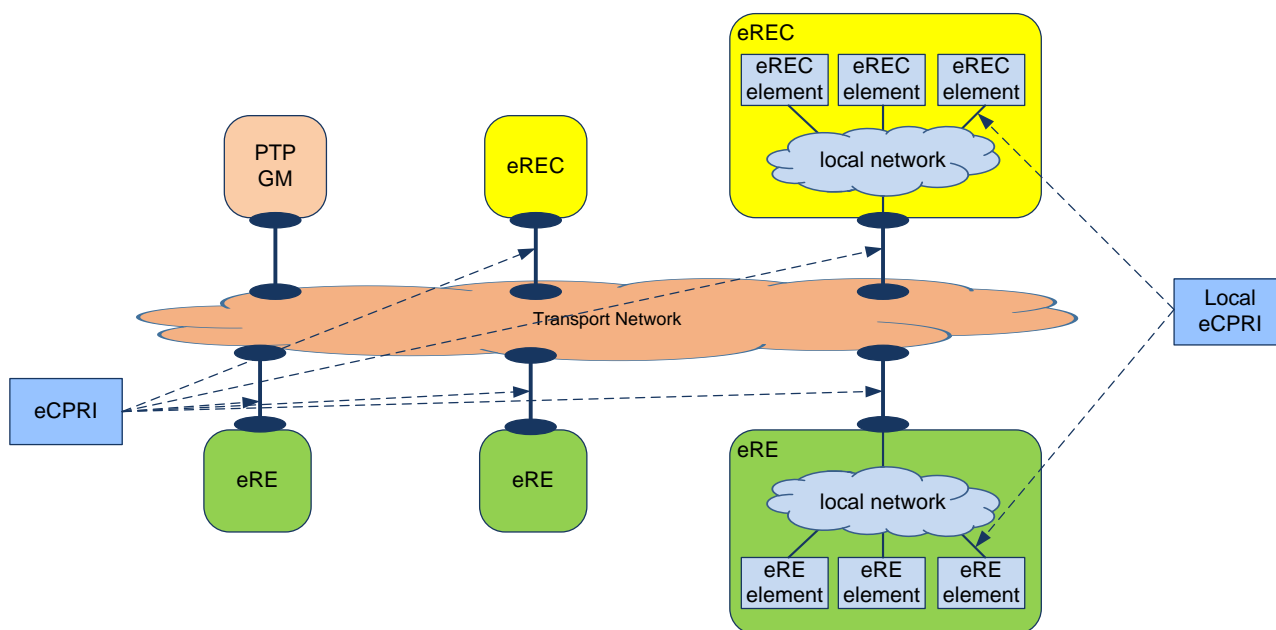

Figure 3: System Architecture example with local eCPRI

1  
2  
3

## 2.3. Functional Description

5 This section provides a description of the functional content of an eNB/gNB. The CPRI concept of a radio  
 6 base station divided into two nodes, one called REC (Radio Equipment Control) and the other called RE  
 7 (Radio Equipment) is still valid for eCPRI but with the small change of renaming the two nodes to eREC and  
 8 to eRE. The functional split across these two nodes can be outlined more flexibly than in the CPRI  
 9 specification. The functional content of an eNB/gNB (eREC and eRE) is listed in Table 1, references to  
 10 corresponding 3GPP Technical Specifications are included in the table.

11 Table 1: Functional content of eNB/gNB

Functions and Protocol Stack of eNB/gNB eREC + eRE	3GPP eNB Reference TS 36.nnn [2]	3GPP gNB Reference TS 38.nnn [3]
Radio Base Station Control & Management	-	-
Backhaul transport	-	-
RRC (Radio Resource Control)	331	331
PDCCP (Packet Data Convergence Protocol)	323	323
RLC (Radio Link Control)	322	322
MAC (Medium Access Control)	321	321
PHY (Physical)	201 (General description)	201 (General description)
RF (Radio Functions)	104	104, 133
Measurements	214, 314	215

12

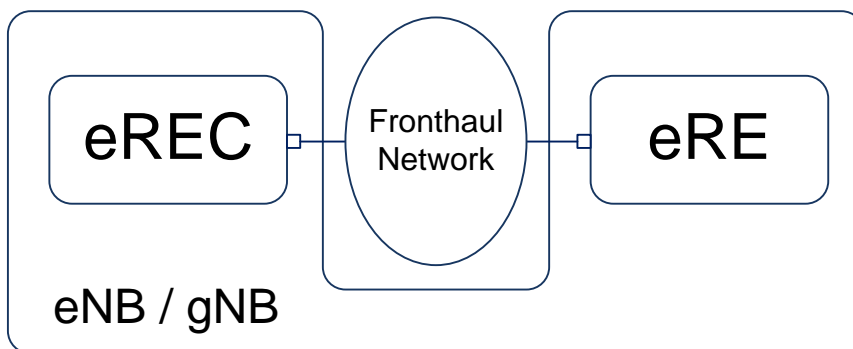

Figure 4: Fronthaul Network definition

Regardless of which functional decomposition between eREC and eRE is selected for a specific implementation, the 'Fronthaul Network' is the interface between the two eCPRI nodes eREC and eRE.

The different functions listed in Table 1 can be located either in the eREC or in the eRE. When using eCPRI for either existing or forthcoming radio standards such as the 3GPP 5G (NR) the functional decomposition between eREC and eRE depends on vendor specific choices. Different implementations will be targeting different objectives (radio performance, fronthaul performance adaptations, feature necessity circumstances etc.) leading to a different functional decomposition between eREC and eRE.

### 2.3.1. Functional Decomposition

Figure 5 shows the protocol stack layers for a 3GPP 4G (LTE) or 5G (NR) radio base station. Five inter-layer functional splits numbered A to E are depicted in the figure. One additional set of intra-PHY splits named  $\{I_b, II_b, I_v\}$  is also shown. For more details of the intra-PHY splits refer to section 6.1.1.

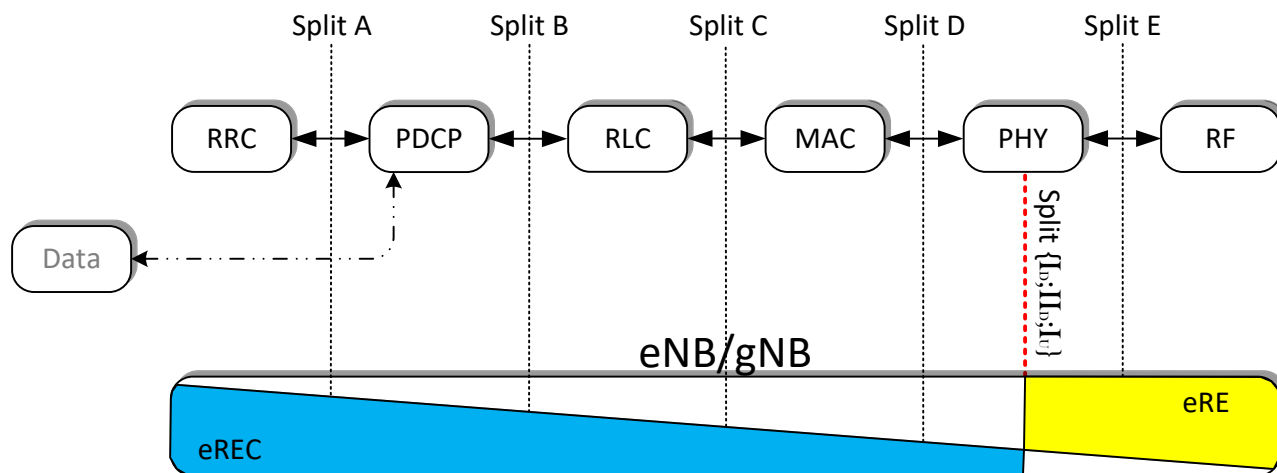

Figure 5: Functional decomposition on RAN layer level

As shown in Figure 5 the eNB/gNB consists of only two units: the eREC and the eRE. For some of the splits an implementation with only two nodes may not be realistic. For instance, Split A with a central RRC and a distributed unit containing the rest of the protocol stack would not support a number of features (such as those requiring cell-coordination) efficiently. eCPRI assumes that the eNB/gNB consists of eREC and eRE(s) only and thus the following text should be read with this in mind. The intra PHY Split is marked with a red line, this is just an example showing how the figure shall be interpreted, the blue and yellow colored areas in a eNB/gNB show what parts are located in eREC and eRE.

The CPRI specification [1] functional decomposition-split for E-UTRA corresponds to split E.

The advantages of the intra-PHY-split are: features such as Carrier Aggregation, Network MIMO, Downlink CoMP, Uplink L1 Comp Joint Processing can be efficiently supported. Some of these features might of course be supported by other splits as well.

Some disadvantages of the intra-PHY-split are: A fronthaul network with "higher" capacity and "lower" latency is required compared to higher layer splits.



1 Table 2 shows how different splits will set different relative capacity- and latency-requirements on the  
 2 fronthaul network.

3 Table 2: Fronthaul requirements vs. splits

<b>Split</b>	<b>Fronthaul capacity needs</b>	<b>Fronthaul latency requirement</b>
<b>A</b>	Low, Scales with # MIMO layers	Relaxed
<b>B</b>	Low, Scales with # MIMO layers	Relaxed
<b>C</b>	Low, Scales with # MIMO layers	Relaxed
<b>D</b>	Low, Scales with # MIMO layers	Very Strict
<b>E</b>	Very High, Scales with # antenna ports	Very Strict
<b>{L<sub>u</sub>;L<sub>u</sub>;L<sub>v</sub>}</b>	See section 6.1.1	Very Strict

4

---

## 1 3. Interface Specification

### 2 3.1. Protocol Overview

3 The eCPRI interface includes the following information flows:

4 1. User Plane:

5 ○ User Data:

6 User information (to be transmitted from/to the base station to/from the user equipment)  
7 with format depending on the underlying functional decomposition between the eREC and  
8 the eRE.

9 ○ Real-Time Control data:

10 Time-critical control and management information directly related to the User Data.

11 ○ Other eCPRI services:

12 eCPRI services such as User Plane support, remote reset, etc.

13 2. C&M Plane:

14 ○ Control and management information exchanged between the control and management  
15 entities within the eREC and the eRE. This information flow is conveyed to the higher  
16 protocol layers and is not considered time critical.

17 3. Synchronization Plane:

18 ○ Synchronization data used for frame and time alignment.

19 eCPRI defines a protocol for the transfer of user plane information between eREC and eRE via a packet  
20 based fronthaul transport network. For C&M and synchronization information flows, existing protocols and  
21 standards are referenced as proposals. The interface supports Ethernet-switched or IP-routed fronthaul  
22 networks. Figure 6 provides an overview on the basic protocol hierarchy for Ethernet/IP-based eCPRI  
23 transport case.

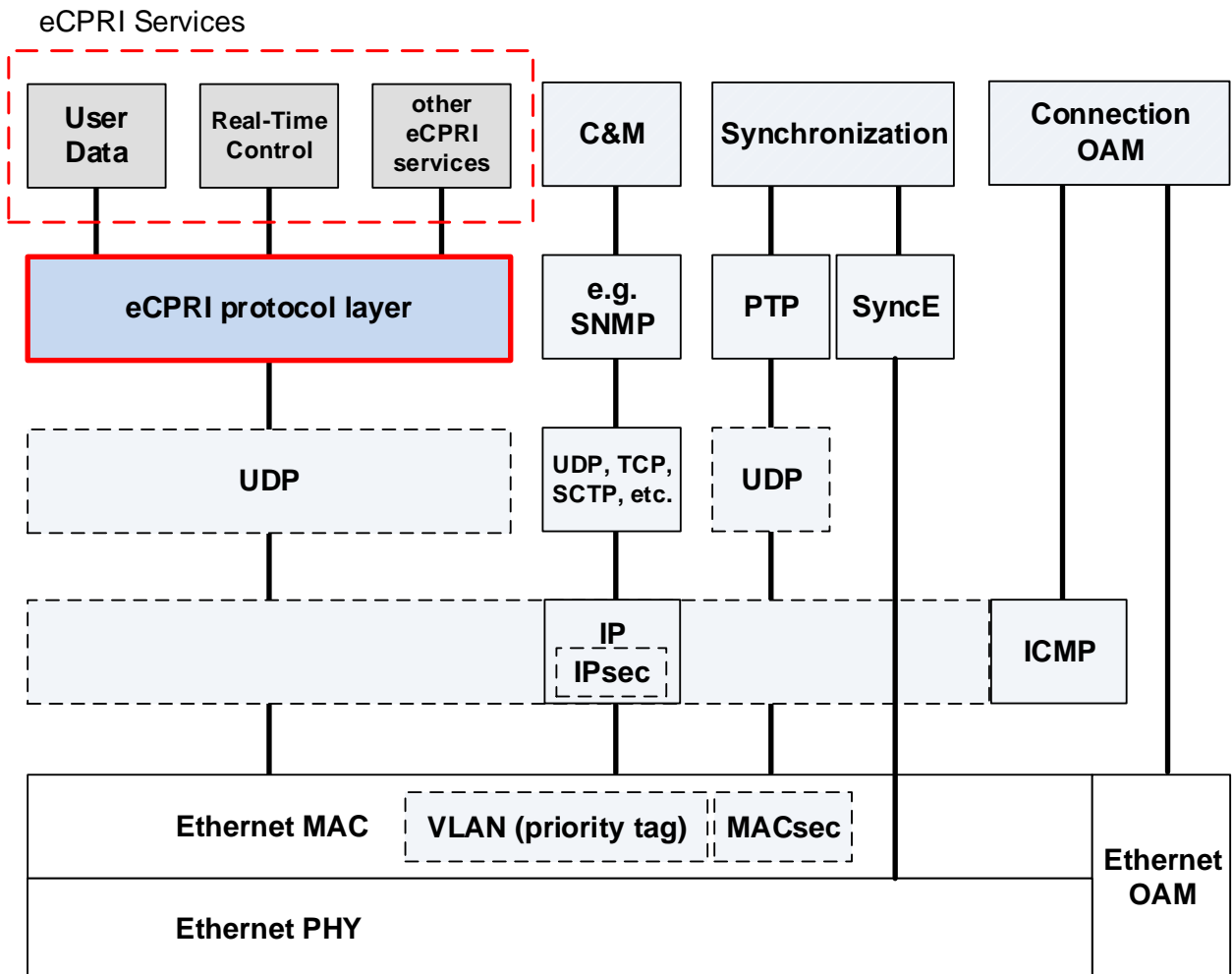

1  
2 Figure 6: eCPRI protocol stack over IP / Ethernet

3 For the example of IP/Ethernet based eCPRI transport protocol shown in Figure 6, the following needs to be  
4 considered:

- 5 • User Plane:
- 6 ○ In case of eCPRI over Ethernet (refer to section 3.2.1) UDP/IP is not used for the User plane.
- 7 ○ In case of eCPRI over IP (refer to section 3.2.2), Ethernet might not be used, even though Ethernet  
8 is still a typical technology used to transfer IP packets.
- 9 ○ Message types used by eCPRI are described in section 3.2.3 in detail.
- 10 • C&M Plane:
- 11 ○ Please refer to Section 3.3 “C&M Plane” for more information.
- 12 • Synchronization Plane:
- 13 ○ UDP/IP and VLAN are optional, e.g. the ITU-T PTP telecom profile G.8275.1/Y.1369.1 [4] only  
14 defines PTP transport over Ethernet. Insertion of VLAN tag is not allowed in this profile, IP and  
15 VLAN are thus not possible.
- 16 ○ Please refer to Section 3.4 “Synchronization Plane” and Annex 6.2 “Synchronization and Timing” for  
17 more information.
- 18 • Connection OAM:
- 19 ○ Please refer to Annex 6.4 “Network Connection Maintenance” for more information.
- 20 • Please refer to section 3.1.1 for more information on “Ethernet PHY”.

- 1 • Please refer to section 3.5 “QoS” for more information on “VLAN (priority tag)”.
- 2 • IPsec and MACsec are optional. Please refer to informative Annex 6.8 “Security” for more information.

### 3 3.1.1. Physical Layer

4 The Physical Layer typically follows electrical and optical physical reference standards provided in IEEE  
5 802.3 [5], [6] for the following eCPRI use cases:

- 6 1. eCPRI over electrical cable
- 7 2. eCPRI over electrical backplane
- 8 3. eCPRI over optical fiber

9 A high flexibility in the choice of connector and transceiver for the optical fiber use case can be achieved by  
10 adopting SFP+ [7], [8] and QSFP+ [9], [10].

11 However, usage of different form factors like CFP, CFP2/4 is not precluded by the eCPRI specification.

12 The following Table 3 lists typical examples of common Ethernet interface types for 10G, 25G, 40G and  
13 100G Ethernet for the given use cases. Usage of other line rates / interface types is not precluded.

14 Table 3: Common Ethernet interface types for the given use cases

Use case	Standard / Interface Type	#Lanes	Signal Rate per Lane
Optical	10GBASE-SR/LR/ER ([5], clause 52)	1	10G
	10GBASE-LRM ([5], clause 68)	1	10G
	25GBASE-SR, LR, ER ([6], [19])	1	25G
	40GBASE-SR4 LR4/ER4 ([5], clauses 86/87)	4	10G
	100GBASE-SR10 ([5], clause 86)	10	10G
	100GBASE-SR4/LR4/ER4 ([5], clauses 95/88)	4	25G
Electrical	25GBASE-CR/CR-S ([6])	1	25G
	40GBASE-CR4 ([5], clause 85)	4	10G
	100GBASE-CR10 ([5], clause 85)	10	10G
	100GBASE-CR4 ([5], clause 92)	4	25G
Backplane	10GBASE-KR ([5], clause 72)	1	10G
	25GBASE-KR/KR-S ([6])	1	25G
	40GBASE-KR4 ([5], clause 84)	4	10G
	100GBASE-KR4 ([5], clause 93)	4	25G

15

## 16 3.2. User Plane

### 17 3.2.1. User Plane over Ethernet

18 In this option, eCPRI messages shall be transmitted in standard Ethernet frames<sup>1</sup> [5]. The Ethernet network  
19 shall follow the definitions in [15].

20 The type field of the Ethernet frame shall contain the eCPRI Ethertype (AEFE<sub>16</sub>) [11]. The data field of the  
21 Ethernet frame shall contain the eCPRI common header at the beginning, followed immediately by the  
22 eCPRI payload. The eCPRI message shall be embedded in the Ethernet frame as a series of octets.

<sup>1</sup> Also, frames with a payload size larger than 1500 octets can be supported

1 As the minimum size of the data field of an Ethernet frame is 46 octets, if necessary, the eCPRI data field is  
2 padded with octets of zero to fill up this minimum size. This padding is not part of the eCPRI message and so  
3 is not to be included in the eCPRI payload size field.

4 An eCPRI node involved in an eCPRI over Ethernet message exchange shall have at least one Ethernet  
5 MAC address. All Ethernet MAC addresses within the Ethernet network shall be unique<sup>2</sup>. The assignment of  
6 Ethernet MAC addresses to nodes/eCPRI services is out of scope of the eCPRI specification.

7 The Ethernet MAC header shall provide enough information about the source and the destination of the  
8 eCPRI message to deliver the message successfully through the Ethernet network, with the required priority.  
9 Further details of the format and definition of the Ethernet frame are out of scope of the eCPRI specification.

### 10 3.2.2. User Plane over IP

11 In this option, eCPRI messages shall be transmitted in UDP/IP packets.

12 The data field of the UDP datagram contains the eCPRI common header at its beginning, followed  
13 immediately by the eCPRI payload. The eCPRI message shall be embedded in the UDP datagram as a  
14 series of octets. The UDP datagram shall encapsulate the eCPRI PDU precisely, i.e. without requiring  
15 padding octets added to the eCPRI PDU.

16 An eCPRI node shall have at least one IP address. All IP addresses within the IP network shall be unique<sup>3</sup>.  
17 The assignment of IP addresses to nodes/eCPRI services is out of scope of the eCPRI specification.

18 The header fields of the UDP/IP datagram shall provide enough information about the source and the  
19 destination of the eCPRI message to deliver the message successfully through the IP network, with the  
20 required priority. Further details of the format and definition of the UDP/IP datagram, and how the IP network  
21 is to be maintained are out of the scope of the eCPRI specification.

22 eCPRI does not specify any range of UDP port values to identify the various eCPRI streams.

### 23 3.2.3. eCPRI Message Format

24 eCPRI messages shall have the format shown in Figure 7 and consist of a four byte eCPRI common header  
25 followed by a variable length eCPRI payload.  
26

---

<sup>2</sup> Both locally unique and globally unique Ethernet MAC addresses are applicable.

<sup>3</sup> There is no restriction on the IP version (IPv4 or IPv6) used in the IP-routed fronthaul network.

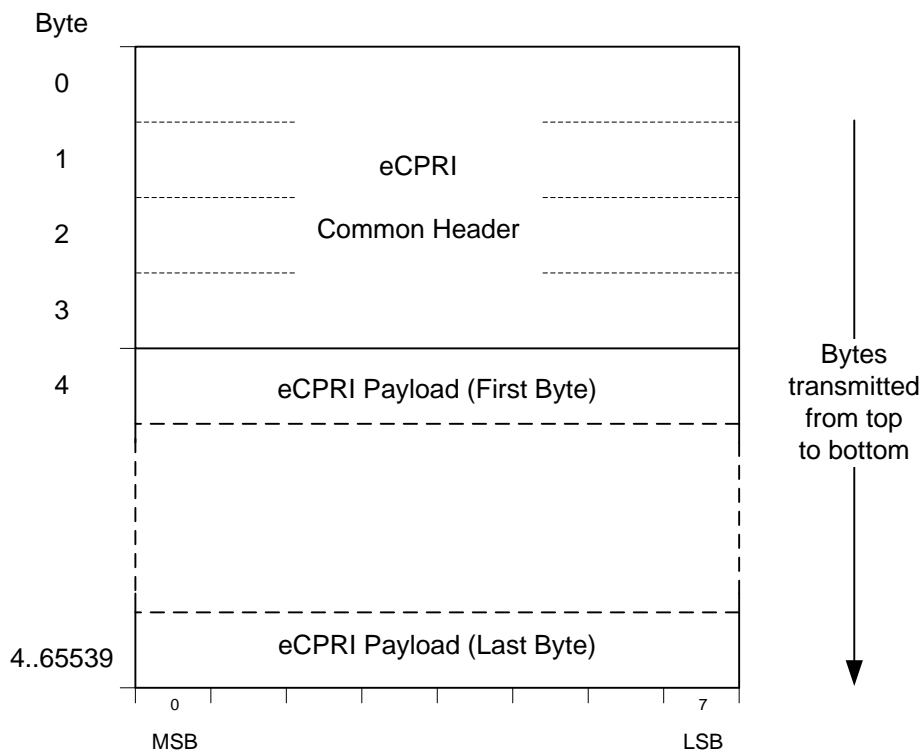

Figure 7: eCPRI message format

1  
2  
3

3.2.3.1. eCPRI Transmission Byte Order

When the range of a field is too large to fit in a single byte, multiple bytes are used to encode that field. For eCPRI, the transmission byte order follows “network byte order” or “big endian”, i.e. the most significant byte is sent first and the least significant byte is sent last (see [12]).

Example:

The hexadecimal number 0xABCD1234 is sent as the byte sequence 0xAB, 0xCD, 0x12, 0x34.

3.2.3.2. Common Header

eCPRI Message Common Header shall have the format shown in Figure 8.

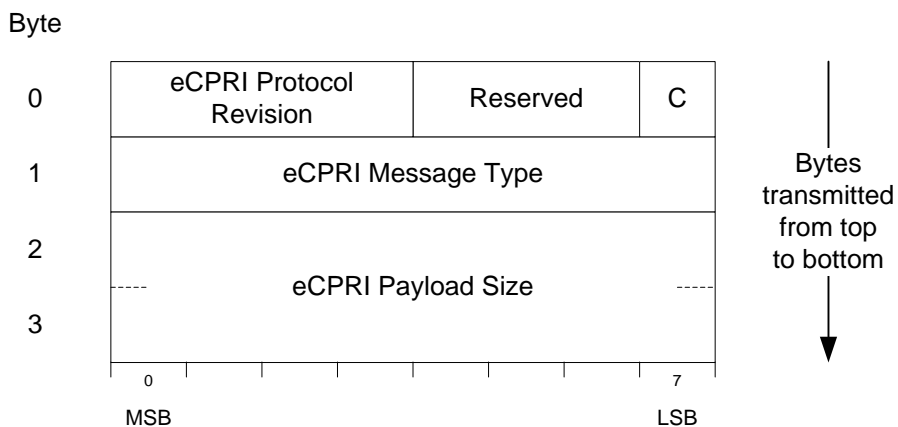

Figure 8: eCPRI Common Header format

12  
13

1 Where:

- 2 • eCPRI Protocol Revision indicates the protocol version.  
3 The eCPRI Protocol Revision is a positive integer value, see section 4.4.
- 4 • eCPRI Message Type (1 byte, see Table 4) indicates the type of service conveyed by the message.
- 5 • eCPRI Payload Size is the size in bytes of the payload part corresponding to the eCPRI message. It  
6 does not include any padding bytes following the eCPRI message. The maximum supported payload  
7 size is  $2^{16}-1$  but the actual size may be further limited by the maximum payload size of the underlying  
8 transport network.
- 9 • "C" is the eCPRI messages concatenation indicator.
  - 10 ○ "C=0" indicates that the eCPRI message is the last one inside the eCPRI PDU.
  - 11 ○ "C=1" indicates that another eCPRI message follows this one within the eCPRI PDU. In this case, 0  
12 to 3 padding byte(s) shall be added to ensure that the following eCPRI message starts at a 4-Byte  
13 boundary. Padding byte(s) shall be ignored when received.
- 14 • Reserved bits shall be handled according to section 4.2.

### 15 3.2.3.3. eCPRI Payload

16 The payload of eCPRI messages shall follow the format specified in the corresponding eCPRI Message  
17 Type sub-section of section 3.2.4. An eCPRI message payload typically includes an eCPRI message header  
18 and its associated eCPRI message user data.

### 19 3.2.3.4. Mapping Examples

20 This section explains how eCPRI messages are mapped onto a transport network layer payload with  
21 examples.

22 Figure 9 shows an example in which one eCPRI message is mapped onto a transport network layer payload  
23 (e.g. UDP/IP or Ethernet).

24 Figure 10 shows an example in which two eCPRI messages are concatenated and mapped onto a transport  
25 network layer payload (e.g. UDP/IP or Ethernet).

26

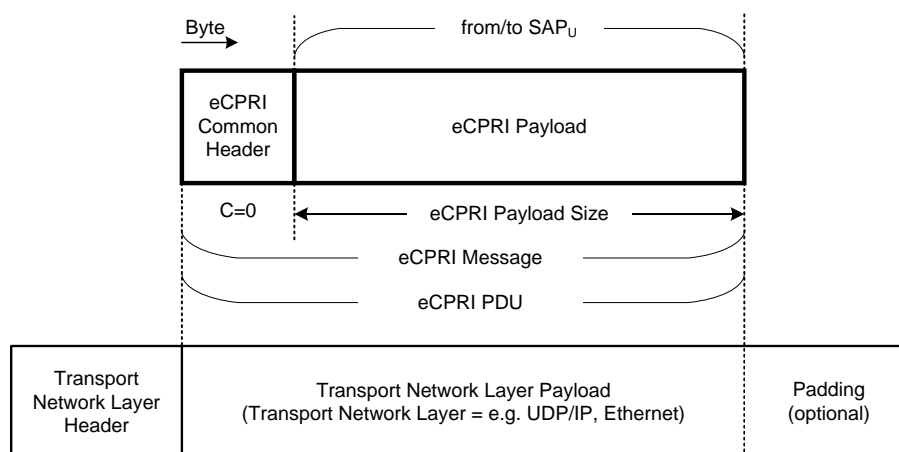

27

28

29

Figure 9: An example of non-concatenated case

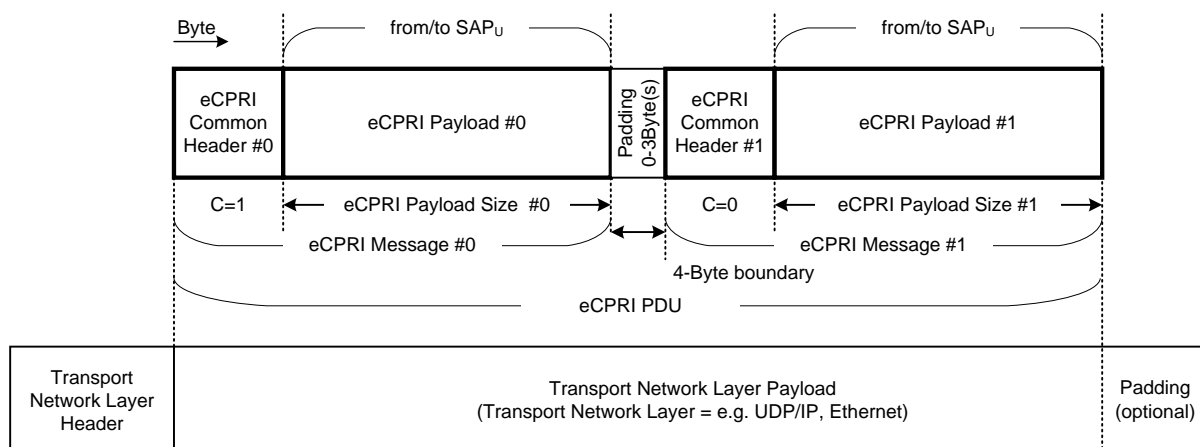

Figure 10: An example of two concatenated eCPRI messages

### 3.2.4. Message Types

The message types listed in Table 4 are supported by eCPRI. The usage of these types is optional.

Table 4: eCPRI Message Types

Message Type #	Name	Section
0	IQ Data	3.2.4.1
1	Bit Sequence	3.2.4.2
2	Real-Time Control Data	3.2.4.3
3	Generic Data Transfer	3.2.4.4
4	Remote Memory Access	3.2.4.5
5	One-way Delay Measurement	3.2.4.6
6	Remote Reset	3.2.4.7
7	Event Indication	3.2.4.8
8 - 63	Reserved	3.2.4.9
64 - 255	Vendor Specific	3.2.4.10

#### 3.2.4.1. Message Type #0: IQ Data

##### 3.2.4.1.1. Description/Usage

This message type is used to transfer time domain or frequency domain IQ samples between PHY processing elements split between eCPRI nodes (eREC and eRE).

##### 3.2.4.1.2. Message format

Figure 11 shows IQ Data Transfer message format.



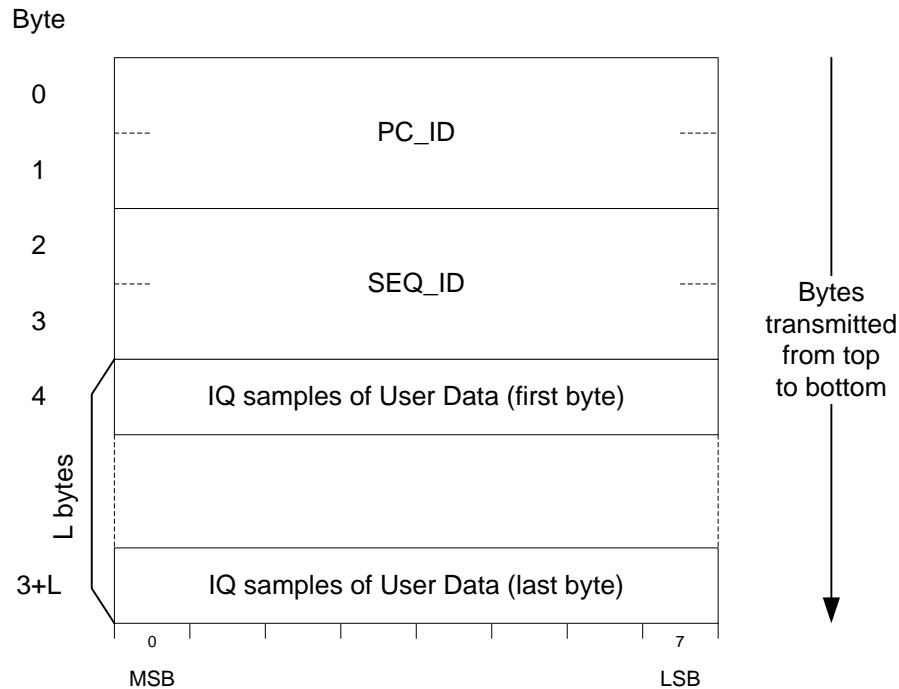

Figure 11: IQ Data Transfer message format

Where:

- **PC\_ID:**
  - An identifier of a series of “IQ Data Transfer” messages.
  - For example, identifier of a physical channel, a user, a layer, an antenna port, etc. which has a common property for PHY processing.
  - How to allocate values to PC\_ID is vendor specific.
- **SEQ\_ID:**
  - An identifier of each message in a series of “IQ Data Transfer” messages.
  - For example, identifier of an OFDM symbol, a block of sub-carriers, etc.
  - How to allocate values to SEQ\_ID is vendor specific.
- **IQ Samples of User Data:**
  - A sequence of IQ sample pairs (I, Q) in frequency domain or time domain and associated control information if necessary.
  - Frequency domain IQ or time domain IQ depends on the selected functional split between eCPRI nodes and is vendor specific.
  - The bit width of an IQ sample, the number of IQ sample pairs in a message, and the format of IQ samples (e.g. fixed point, floating point, block floating point), etc. are vendor specific. The actual format is known by the transmit/receive eCPRI nodes in advance.

#### 3.2.4.1.3. Message sequence diagram

Figure 12 shows an example of IQ Data Transfer Sequence. In this example:

- A “Real-Time Control Information” message for PC\_ID is transferred before a series of “IQ Data Transfer” messages to inform the remote node how to process IQ samples in following “IQ Data Transfer” messages.
- An “IQ Data Transfer” message with PC\_ID is transferred every OFDM symbol period. Each message has a unique SEQ\_ID.
- In general, multiple transfer sequence may happen in parallel with different PC\_IDs, e.g. for multiple physical channels, users, layers, antenna ports, etc.

1  
2

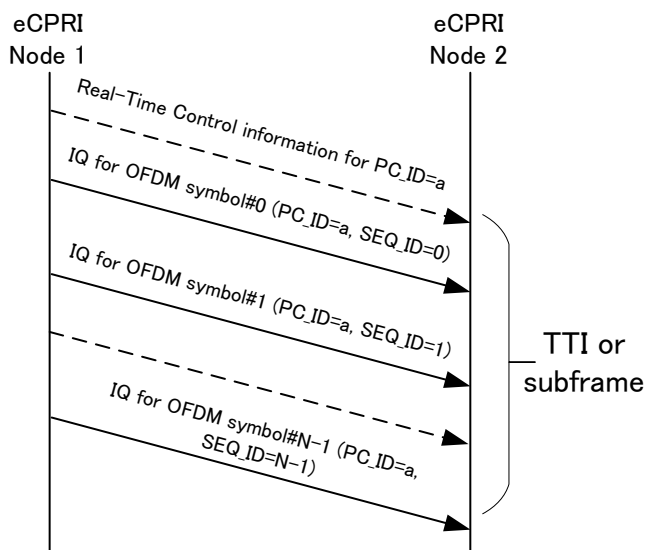

3  
4

Figure 12: Message sequence diagram (example)

5 **3.2.4.2. Message Type #1: Bit Sequence**

6 3.2.4.2.1. Description/Usage

7 This message type is used to transfer user data in form of bit sequence between PHY processing elements  
8 split between eCPRI nodes (eREC and eRE).

9 3.2.4.2.2. Message format

10 Figure 13 shows Bit Sequence Transfer message format.

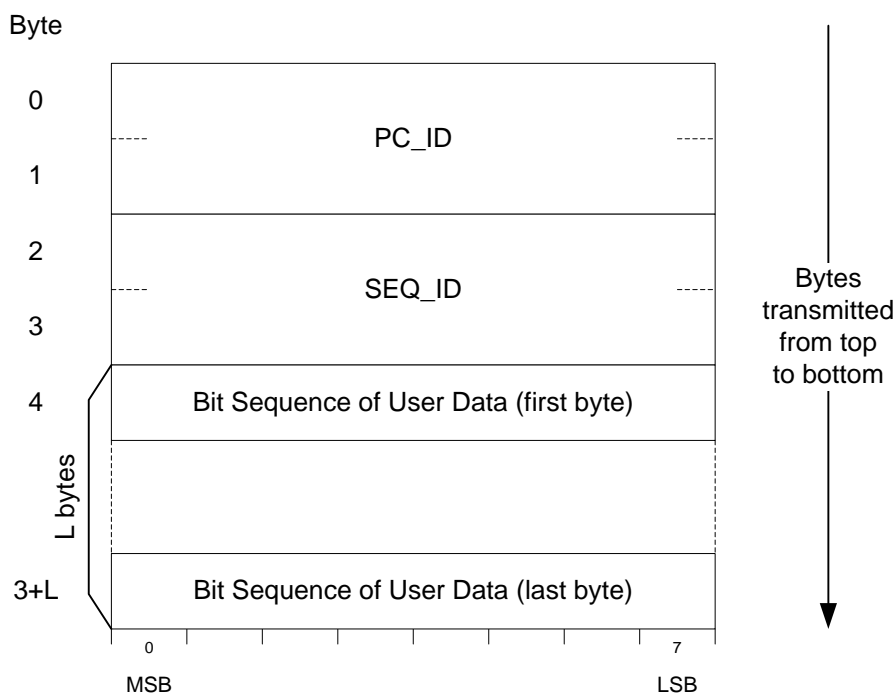

11  
12

Figure 13: Bit Sequence Transfer message format

1 Where:

2 • PC\_ID:

- 3 ○ An identifier of a series of “Bit Sequence Transfer” messages.
- 4 ○ For example, identifier of a physical channel, a user, a layer, an antenna port, etc. which has a
- 5 common property for PHY processing.
- 6 ○ How to allocate values to PC\_ID is vendor specific.

7 • SEQ\_ID:

- 8 ○ An identifier of each message in a series of “Bit Sequence Transfer” messages.
- 9 ○ For example, identifier of an OFDM symbol, a block of sub-carriers, etc.
- 10 ○ How to allocate values to SEQ\_ID is vendor specific.

11 • Bit Sequence of User Data:

- 12 ○ A Bit Sequence of User Data, e.g. channel coded data before modulation mapping.
- 13 ○ The information carried by the Bit Sequence Transfer message depends on the selected
- 14 functional split between eCPRI nodes and is vendor specific.
- 15 ○ The length of a Bit Sequence in a message is vendor specific and known by the transmit/receive
- 16 node in advance.

17 3.2.4.2.3. Message sequence diagram

18 A message sequence example of the Bit Sequence Transfer is shown in Figure 14. In this example:

- 19 • A “Real-Time Control Information” message for PC\_ID=a is transferred prior to a series of “Bit
- 20 Sequence Transfer” messages to inform the remote node how to process the user data in bit sequence
- 21 format in the following “Bit Sequence Transfer” messages.
- 22 • A “Bit Sequence Transfer” message with PC\_ID is transferred every OFDM symbol period. Each
- 23 message has a unique SEQ\_ID.
- 24 • In general, multiple transfer sequences may happen in parallel with different PC\_IDs, e.g. for multiple
- 25 physical channels, users, layers, antenna ports, etc.

26

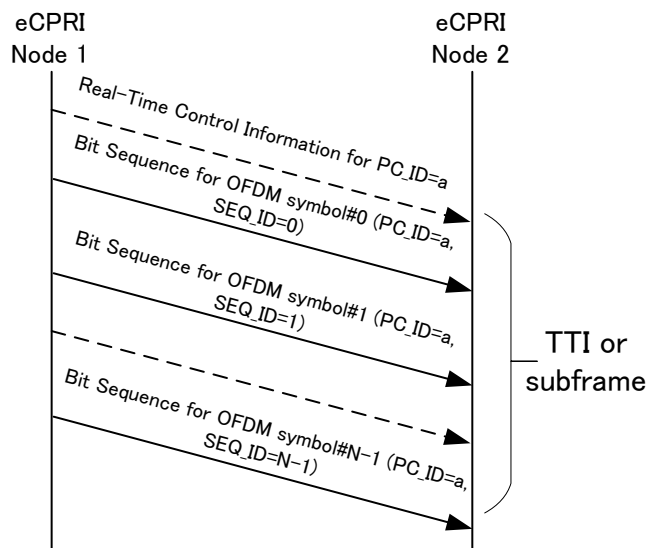

27

28

Figure 14: Message sequence diagram (example)

### 1 3.2.4.3. Message Type #2: Real-Time Control Data

#### 2 3.2.4.3.1. Description/Usage

3 This message type is used to transfer vendor specific real-time control messages between PHY processing  
 4 elements split between eCPRI nodes (eREC and eRE). This message type addresses the need to exchange  
 5 various types of control information associated with user data (in form of IQ samples, bit sequence, etc.)  
 6 between eCPRI nodes in real-time for control/configuration/measurement. However, this type of information  
 7 highly depends on the selected function split and the actual implementation of these functions. So only the  
 8 message type for Real-Time Control Data is defined, but not the data format.

#### 9 3.2.4.3.2. Message format

10 Figure 15 shows the Real-Time Control Data message format.

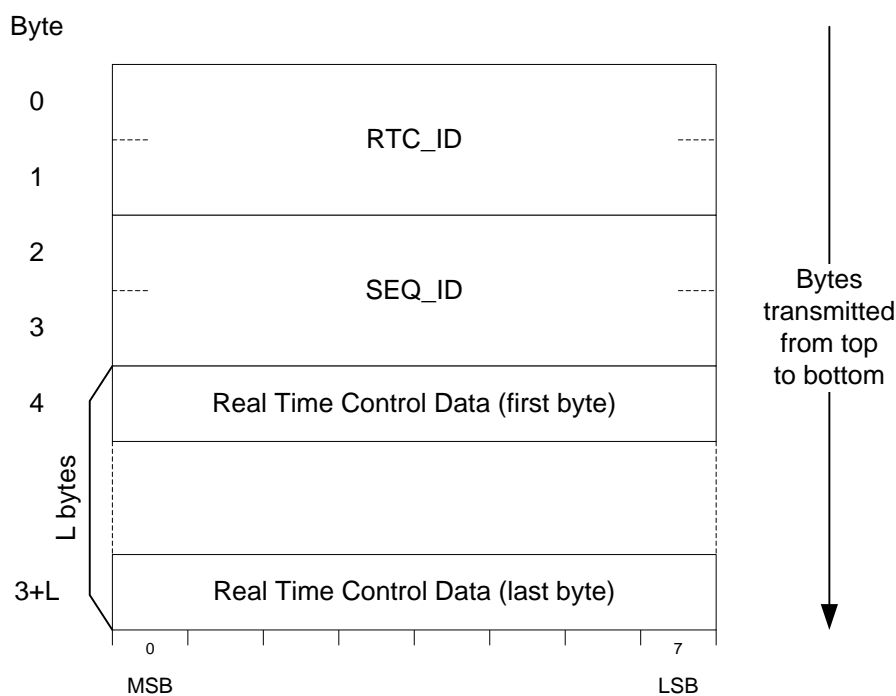

11  
12 Figure 15: Real-Time Control Data Message format

13  
14 Where:

- 15 • RTC\_ID:
  - 16 ○ An identifier of a series of “Real-Time Control Data” messages.
  - 17 ○ For example, identifier for message structures of specific control / configuration / status /
  - 18 measurement and request / response / indication types.
  - 19 ○ How to allocate values to RTC\_ID is vendor specific.
- 20 • SEQ\_ID:
  - 21 ○ An identifier of each message in a series of “Real-Time Control Data” messages.
  - 22 ○ For example, identifier of message sequence, links between request and response messages,
  - 23 etc.
  - 24 ○ How to allocate values to SEQ\_ID is vendor specific.
- 25 • Real-Time Control Data:
  - 26 ○ The format of this part of the payload is vendor specific.

### 1 3.2.4.3.3. Message sequence diagram

2 Figure 16 shows an example of Real-Time Control Message passing sequence. In this example, Real-Time  
 3 Control Messages are transferred prior to and/or after the associated user data messages (in form of IQ Data  
 4 or Bit Sequence).

5

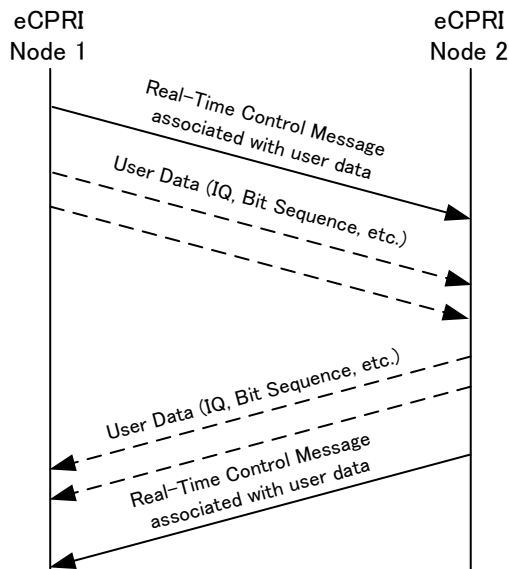

6

7

8

Figure 16: Message Sequence diagram (example)

### 9 3.2.4.4. Message Type #3: Generic Data Transfer

#### 10 3.2.4.4.1. Description/Usage

11 This message type is used to transfer user plane data or related control between eCPRI nodes (eREC and  
 12 eRE) providing extended data synchronization support for generic data transfers.

#### 13 3.2.4.4.2. Message format

14 Figure 17 shows the Generic Data Transfer message format.

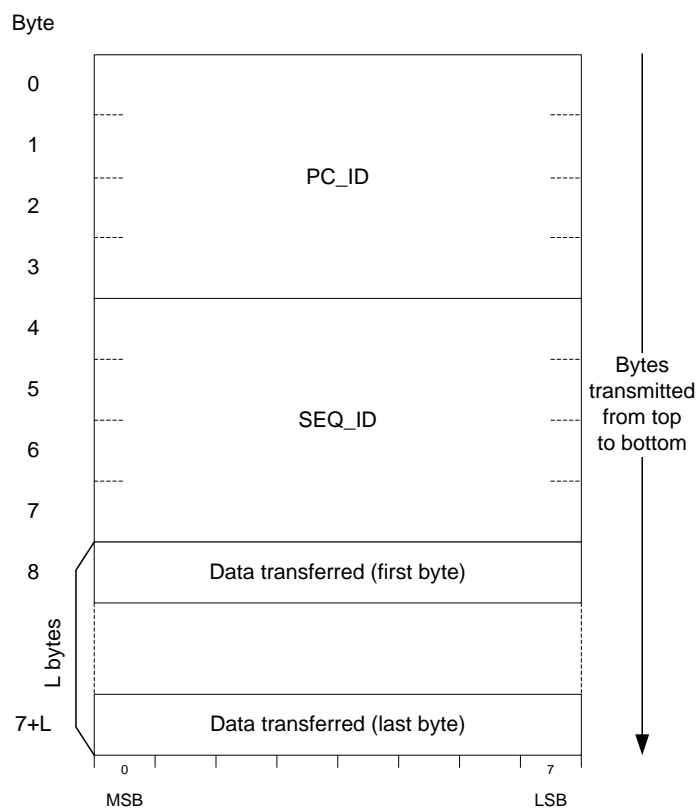

Figure 17: Generic Data Transfer message format

Where:

- **PC\_ID:**

- An identifier of a series of “Generic Data Transfer” messages.
- For example, identifier of a physical channel, a user, a layer, an antenna port, etc. or in case of control, an identifier for control / configuration / status / measurement or other indication.
- How to allocate values to PC\_ID is vendor specific.

- **SEQ\_ID:**

- 4-byte field of each message in a series of “Generic Data Transfer” messages.
- For example, identifier of
  - message sequence
  - data time relation to frame, OFDM symbol, a block of sub-carriers or sub-carrier etc.
  - identifier for completion of transfer phase
- How to allocate values to SEQ\_ID is vendor specific.

- **Data transferred:**

- A sequence of
  - user data samples in frequency or time domain and associated control information if necessary
  - control information
- User or control data content depends on the selected functional split between eCPRI nodes and is vendor specific.
- The sample size, the number of samples etc. in a message, and the format of samples (e.g. fixed point, floating point, block floating point), etc. are vendor specific. The actual format is known by the transmit/receive eCPRI nodes in advance.

### 1 3.2.4.4.3. Message sequence diagram

2 Figure 18 shows an example of Data Transfer Sequence. In this example, Generic Data Transfer message  
3 type is used to transmit “User data”:

- 4 • A “Real-Time Control Information” message for PC\_ID is transferred before a series of “Generic Data  
5 Transfer” messages to inform the remote node how to process Data samples in following “Generic  
6 Data Transfer” messages.
- 7 • An “Generic Data Transfer” message with PC\_ID is transferred e.g. every OFDM symbol period. Each  
8 message has a unique SEQ\_ID.
  - 9 ○ SEQ\_ID does not need to be continuous.
- 10 • In general, multiple transfer sequence may happen in parallel with different PC\_IDs, e.g. for multiple  
11 physical channels, users, layers, antenna ports, etc.

12

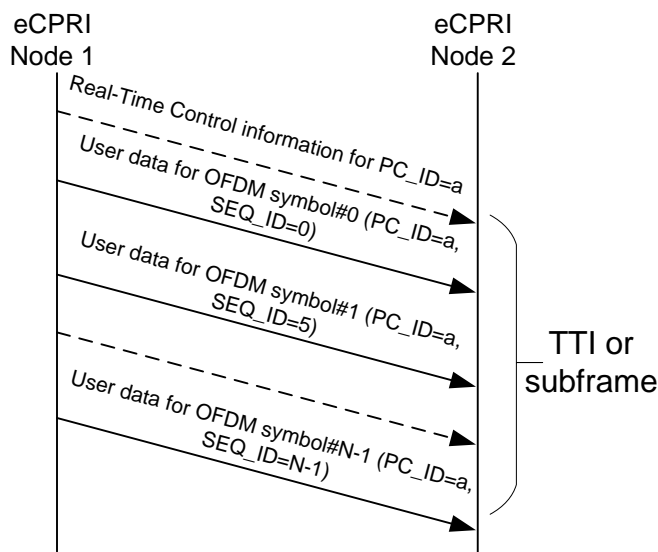

13

14 Figure 18: Message sequence diagram (example)

15

### 16 3.2.4.5. Message Type #4: Remote Memory Access

#### 17 3.2.4.5.1. Description/Usage

18 The message type ‘Remote Memory Access’ allows reading or writing from/to a specific memory address on  
19 the opposite eCPRI node. The service is symmetric i.e. any “side” of the interface can initiate the service.

20 The service is conceived in a generic way to handle different kinds of write and read access that depend on  
21 the hardware used in a specific implementation. It is up to the driver routines for an implementation to map a  
22 write/read request to its hardware implementation.

23 A read or write request/response sequence is an atomic procedure, i.e. a requester needs to wait for the  
24 response from the receiver before sending a new request to the same receiver. A write request without  
25 response is also defined, this procedure is a one-message procedure.

#### 26 3.2.4.5.2. Message format

27 The ‘Remote Memory Access’ message format is shown in Figure 19.

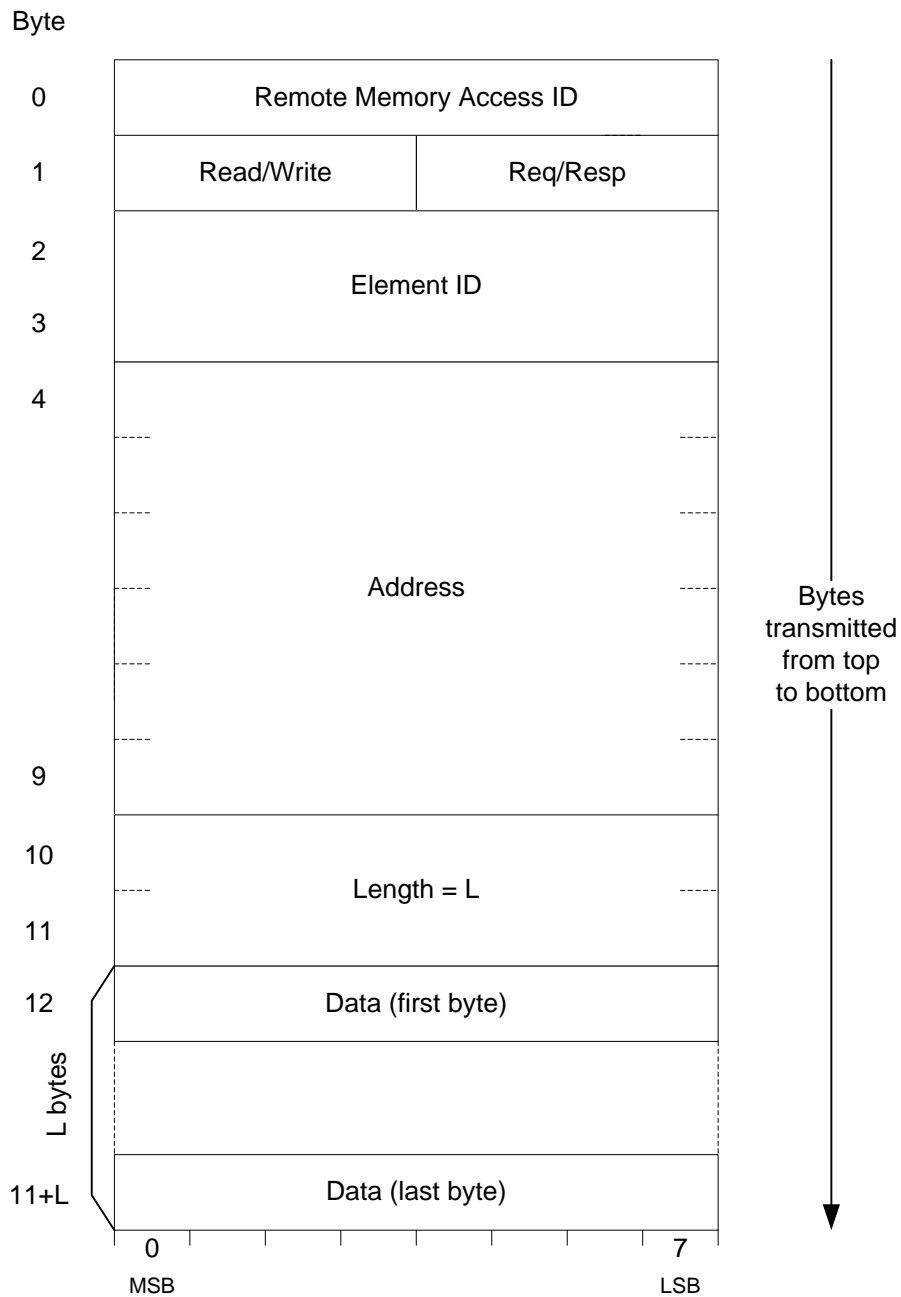

Figure 19: Remote Memory Access message format

Where:

- **Remote Memory Access ID:**  
The Remote Memory Access ID is used by the initiator of the request when the response is received to distinguish between different accesses.
- **Read/Write & Request/Response:**  
The field consist of two parts, a read or write indication and a request or response indication.



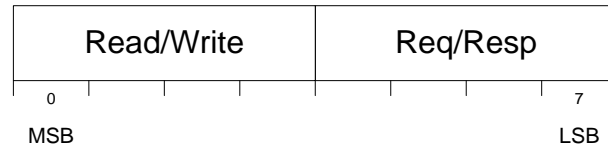

Figure 20: R/W and Req/Resp

The Read/Write and Request/Response fields are coded according to Table 5 and Table 6.

Table 5: Read/Write coding

Value	Read/Write
0000b	Read
0001b	Write
0010b	Write_No_Resp
0011b .. 1111b	Reserved

Table 6: Request/Response coding

Value	Request/Response
0000b	Request
0001b	Response
0010b	Failure
0011b .. 1111b	Reserved

The Response value 0010b (Failure) is used when the receiver of the request is unable to perform the read/write request due to invalid content in received parameters or other faults.

- Element ID:

Depending on implementation the Element ID could be used for instance to point out a specific instance of a generic hardware function.

- Address:

The Address is a 48-bit value. Details such as whether the memory on the opposite node is organized in one or more memory banks or whether an address offset is signaled over the interface etc. are vendor specific. The Element ID could be used for identifying a specific memory hardware instance.

- Length:

For a request, the 2-byte Length field contains the number of bytes that are either to be written to or read from a specific address.

1 For a response, the 2-byte Length field contains the actual number of bytes that were either written or  
 2 read. If for some reason it was not possible to either read or write the full length of data, this will be  
 3 detected via the difference in the length field.

4 • Data:

5 The first Data-byte after the length-field is either the byte that will be written to the memory address  
 6 given in the write request or it is the byte read from the memory address given in the read request.

7 3.2.4.5.3. Message sequence diagram

8 An eCPRI-node can at any time initiate a Remote Memory Access to another node. Depending on if it is a  
 9 request or a response and whether it is a read or write, different fields will be copied or set according to  
 10 Table 7.

11 Table 7: Parameter handling

Action	ID	Read/Write	Req/Resp	Element ID	Address	Length	Data
Read request	Set	Set to Read	Set to Req	Set	Set	Set	No data
Read response	Copied	Copied	Set to Resp	Copied	Copied	Number of read bytes	The read data
Write request	Set	Set to Write	Set to Req	Set	Set	Set	The data to be written
Write response	Copied	Copied	Set to Resp	Copied	Copied	Number of written bytes	No data
Write No response	Set	Set to Write_No_Resp	Set to Req	Set	Set	Set	The data to be written
Failure response	Copied	Copied	Set to Failure	Copied	Copied	Vendor specific	Vendor specific

12

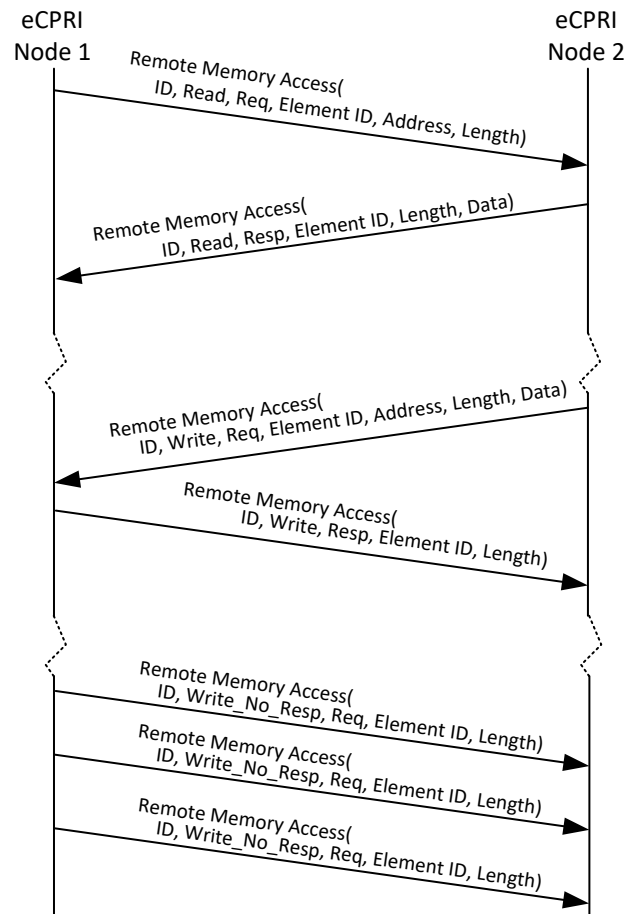

Figure 21: Message sequence diagram (example)

### 3.2.4.6. Message Type #5: One-Way Delay Measurement

#### 3.2.4.6.1. Description/Usage

The message type 'One-Way delay measurement' is used for estimating the one-way delay between two eCPRI-ports in one direction. The sender of the message will sample the local time ( $t_1$ ) and include a compensation value ( $t_{CV1}$ ) and send it to the receiver. The receiver will time stamp the message when it arrives ( $t_2$ ) and send that together with an internal compensation value ( $t_{CV2}$ ) back to the sender. The one-way delay measurement can be performed without or with a Follow\_Up message (1-Step and 2-Step versions). The decision of which version to use is vendor specific.

The One-Way delay value is calculated according to equation (1):

$$t_D = (t_2 - t_{CV2}) - (t_1 + t_{CV1}) \quad (1)$$

With the two compensation values, it is possible for a specific implementation to set the reference points for the measurements as suited for a specific implementation. The exact locations of the reference points are vendor specific.

Example: Time sampling according to Clause 90 in IEEE 802.3-2015 [5], in this case the time sampling is in between MAC and PHY layers.

The service assumes that both nodes are time synchronized to a common time with an accuracy sufficient for the eCPRI service.

The usage of eCPRI message type 'One-Way delay measurement' regarding which node initiates a transmission, the frequency of measurements, response deadline, etc. is vendor specific.

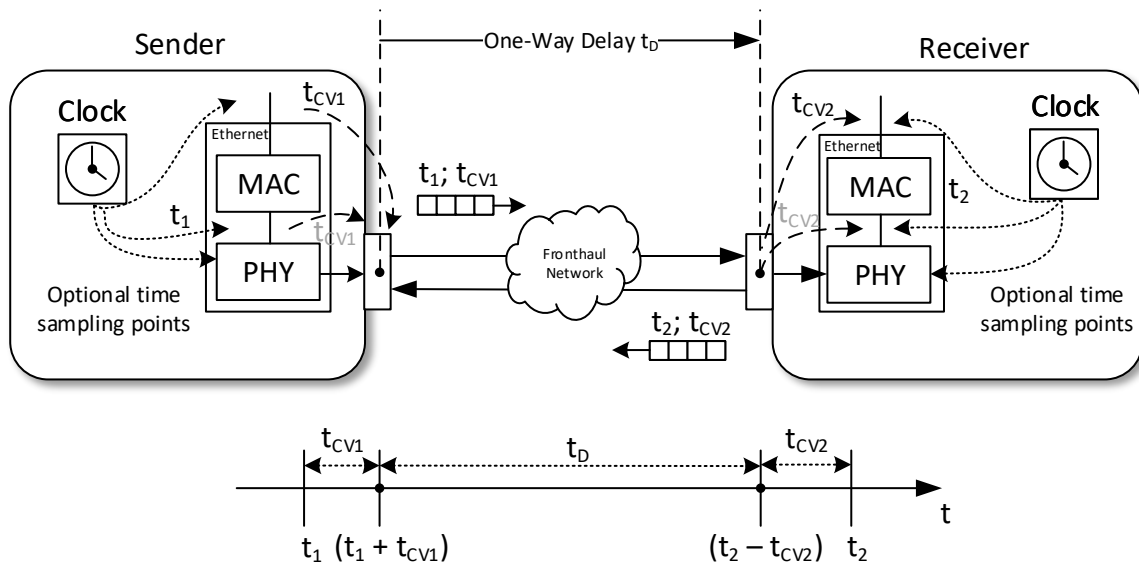

1

2

Figure 22: One-Way delay measurement of the delay Sender -> Receiver

3

3.2.4.6.2. Message format

4

The 'One-Way delay measurement' message format is shown in Figure 23.

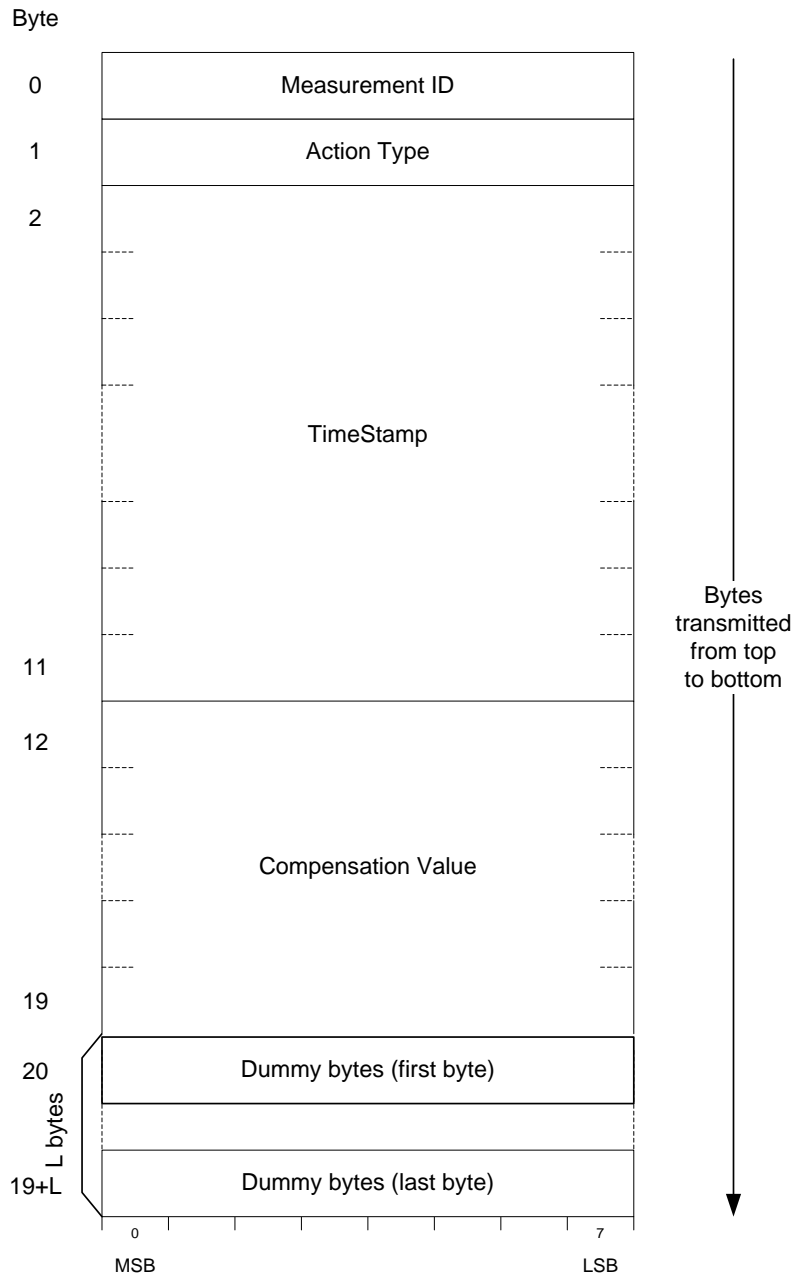

Figure 23: One-Way delay measurement message

Where:

- Measurement ID:

The Measurement ID is a 1-byte value used by the sender of the request when the response is received to distinguish between different measurements, i.e. the receiver of the request shall copy the ID from the request into the response message.

- Action Type:

The Action Type is a 1-byte value described in Table 8.

1

Table 8: Action Type

Action Type	Description
0x00	Request
0x01	Request with Follow_Up
0x02	Response
0x03	Remote Request
0x04	Remote request with Follow_Up
0x05	Follow_Up
0x06 ... 0xFF	Reserved

2 Value 0x00 and 0x01 are used when an eCPRI node initiates a one-way delay measurement in  
 3 direction from its own node to another node. Value 0x02 is used when an eCPRI node needs to know  
 4 the one-way delay from another node to itself. See section 3.2.4.6.3 for usage.

5 • TimeStamp:

6 When Action Type is set to 0x00 (Request) in the message this field will contain the time stamp  $t_1$  and  
 7 when Action Type is set to 0x02 (Response) the time stamp  $t_2$ . When action type is set to 0x01  
 8 (Request with Follow\_Up) the time stamp information fields shall be set to 0b in all bits, the  
 9 corresponding time information values are sent in the Follow\_Up message.

10 When Action Type is set to 0x03 or 0x04 (Remote Request and Remote Request with Follow\_Up) the  
 11 time stamp information fields shall be set to 0b in all bits.

12 When using the Follow\_Up message (2-Step version) the Follow\_Up message (Action Type set to  
 13 0x05) the time information values  $t_1$  and  $t_{CV1}$  will be set to the TimeStamp field.

14 The time information values follow the format specified in IEEE 1588-2008 [13] Clause 5.3.3.

15 The value consists of 2 parts, one 'seconds'-part and one 'nanoseconds'-part. The first 6 bytes are the  
 16 seconds and the next 4 bytes are the nanoseconds.

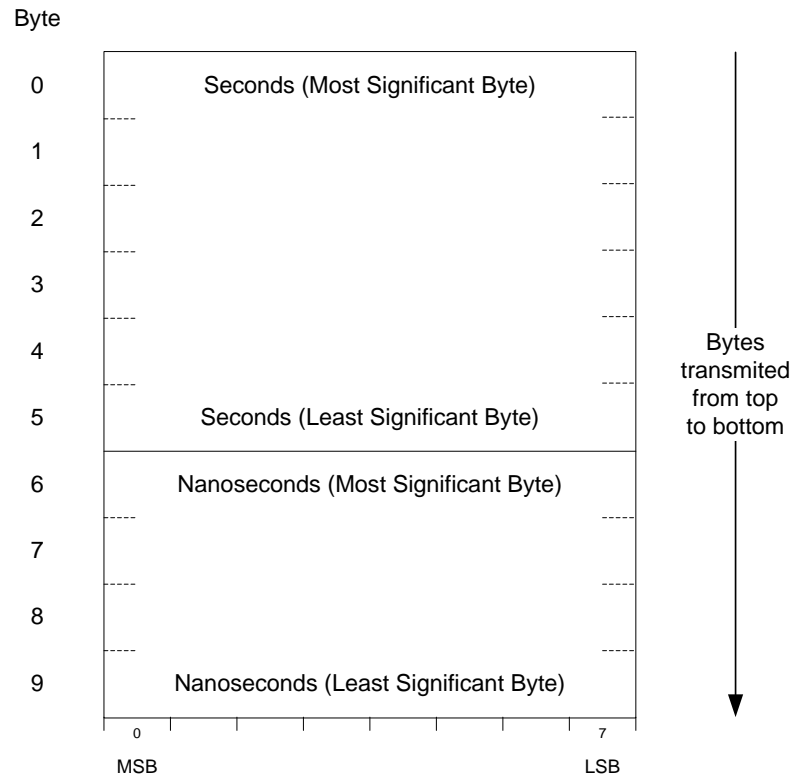

Figure 24: TimeStamp

- Compensation value:

When Action Type is set to 0x00 (Request), 0x02 (Response) or 0x05 (Follow\_Up) in the message, this field will contain the 'Compensation Value' which is the compensation time measured in nanoseconds and multiplied by  $2^{16}$  and follows the format for the correctionField in the common message header specified in IEEE 1588-2008 Clause 13.3 [13]. When Action Type is set to 0x03 (Remote Request) or 0x04 (Remote Request with Follow\_Up) the time information fields TimeStamp and Compensation Value are set to 0b in all bits.

A Compensation Value of 0 (zero) is a valid value.

Example: A Compensation Value of 183.5 ns is represented as  $0000000000B78000_{16}$ .

- Dummy bytes:

The number of dummy bytes included in the eCPRI-payload will be defined by the eCPRI payload size field in the eCPRI common header, see section 3.2.3.1

Due to network characteristics, a small message might take shorter time through the network than a large one, with the dummy bytes the one-way delay estimation can be improved.

The insertion of dummy bytes is only needed when the Action Type set to 0x00 (Request) or to 0x01 (Request with Follow\_Up).

### 3.2.4.6.3. Message sequence diagram

The message sequence diagram shown in Figure 25 is divided in 2 parts:

Part I shows the sequence when Node 1 initiates a delay measurement in the direction Node 1 to Node 2.

Part II shows the sequence when Node 1 initiates a delay measurement in the direction Node 2 to Node 1.

An eCPRI-node can at any time initiate a one-way delay measurement by setting the Action Type to 0x00 (Request), 0x01 (Request with Follow\_Up) 0x03 (Remote Request) or 0x04 (Remote Request with Follow\_Up). The Measurement ID received in the request shall be copied in the response.

Figure 26 shows the same sequences as Figure 25 but with the usage of the Follow\_Up message.

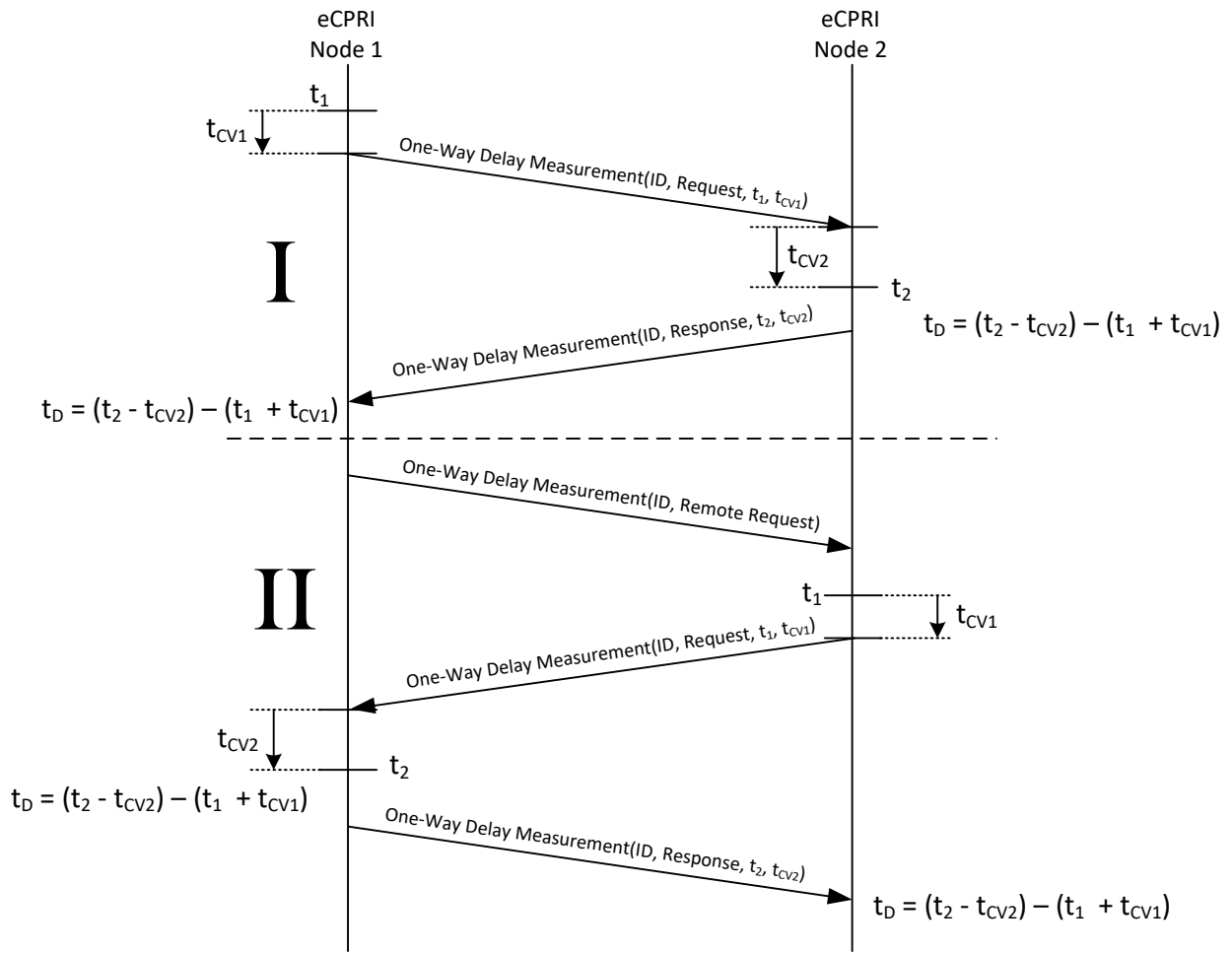

1  
2  
3  
4

Figure 25: Message sequence diagram without Follow\_Up (example)



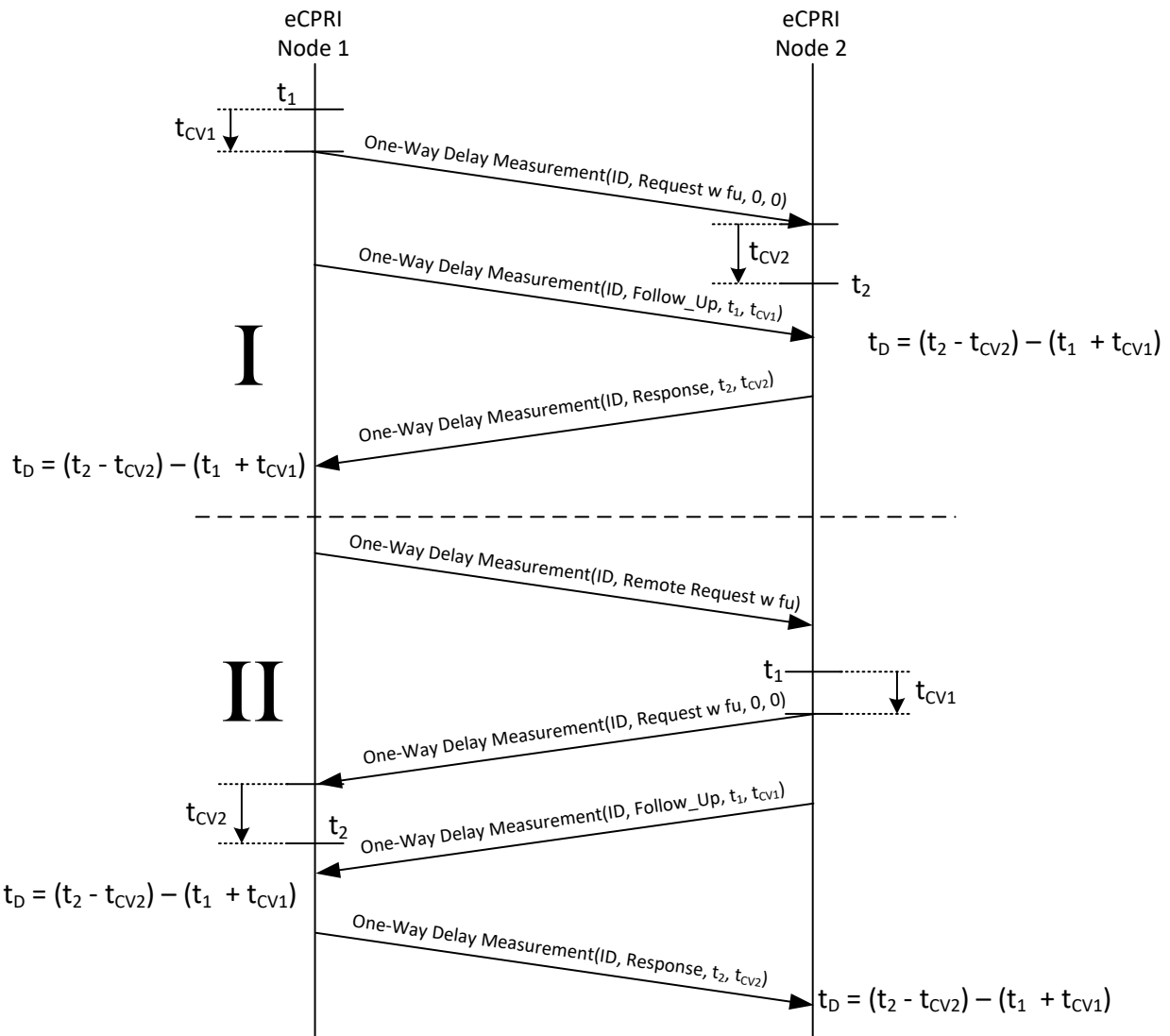

Figure 26: Message sequence diagram with Follow\_Up (Example)

### 3.2.4.7. Message Type #6: Remote Reset

#### 3.2.4.7.1. Description/Usage

This message type is used when one eCPRI node requests reset of another node. A “Remote Reset” request sent by an eREC triggers a reset of an eRE. Upon reception of a valid “Reset request”, the eRE should send a “Remote Reset” Indication before performing the requested reset.

#### 3.2.4.7.2. Message format

Figure 27 shows the Remote reset message format.

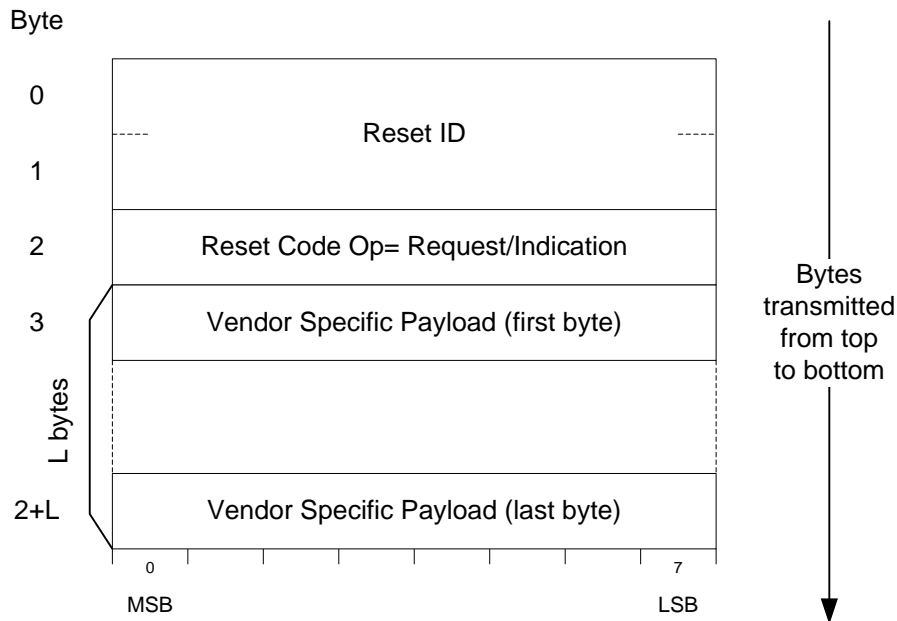

Figure 27: Remote reset message format

Where:

- **Reset ID:**
  - Depending on implementation the Reset ID could be used for instance to point out a specific instance of a generic hardware function.
  - How to allocate values to Reset ID is vendor specific.
- **Reset Code Op:**

The Reset Code Op is a 1-byte value described in Table 10.

Table 9: Reset Code Op

Reset Code Op	Description
0x00	Reserved
0x01	Remote reset request
0x02	Remote reset response
0x03,,,0xFF	Reserved

- **Vendor Specific Payload bytes:**

Vendor Specific Payload bytes are used to carry optional vendor-specific information. The vendor-specific information can contain data items such as authentication parameters or any parameters to select a specific reset behavior. This specification does not detail any concrete reset behavior.

1 3.2.4.7.3. Message sequence diagram

2

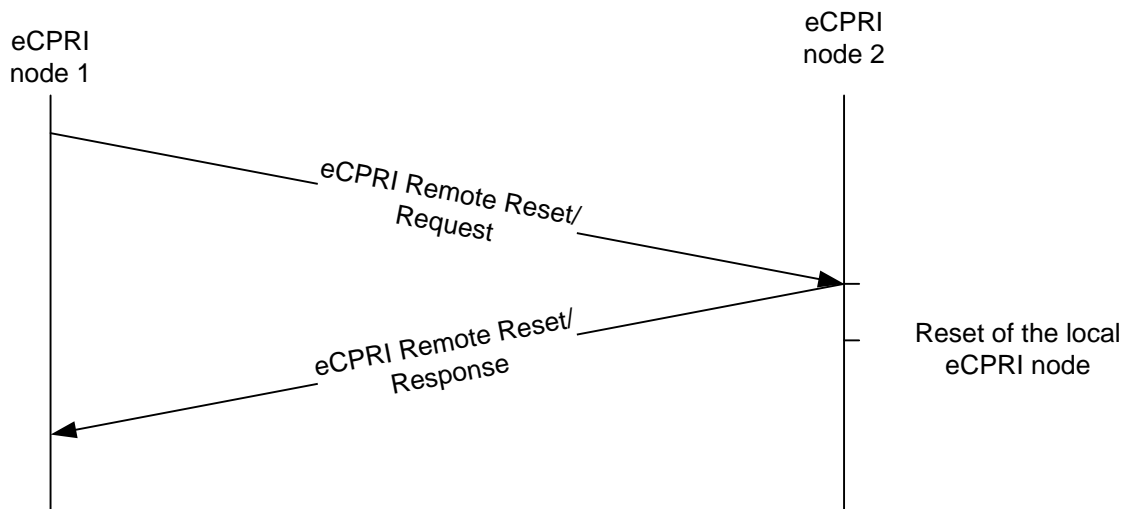

3

4 Figure 28: Message sequence diagram (example)

5 3.2.4.8. Message Type #7: Event Indication

6 3.2.4.8.1. Description/Usage

7 The message type 'Event Indication' is used when either side of the protocol indicates to the other end that  
 8 an event has occurred. An event is either a raised or ceased fault or a notification. Transient faults shall be  
 9 indicated with a Notification.

10 Faults/Notifications sent on eCPRI level should be relevant to the eCPRI services. For instance, faults in the  
 11 user plane processing, power usage fault situations etc. The faults and notifications should be related to the  
 12 user data processing.

13 One Event Indication can either contain one or more faults, or one or more notifications. Faults and  
 14 notifications cannot be mixed in the same Event Indication message.

15 Other faults/notifications related to an eCPRI node such as temperature faults, power supervision, etc. would  
 16 normally be sent via the C&M plane.

17 An eCPRI node is modelled as consisting of N Elements, a fault or notification is connected to one Element.  
 18 The detailed mapping of a specific implementation of HW and SW to Elements and their associated  
 19 faults/notification is vendor specific.

20 A fault/notification may be connected to the node itself. In that case a predefined Element ID number is used,  
 21 see Table 11.

22 The Event/Fault Indication message could be sent from an eCPRI node at any time.

23 For consistency check a synchronization request procedure is defined. This procedure will synchronize the  
 24 requester with the current status of active faults. Transient faults will not be synchronized.

1

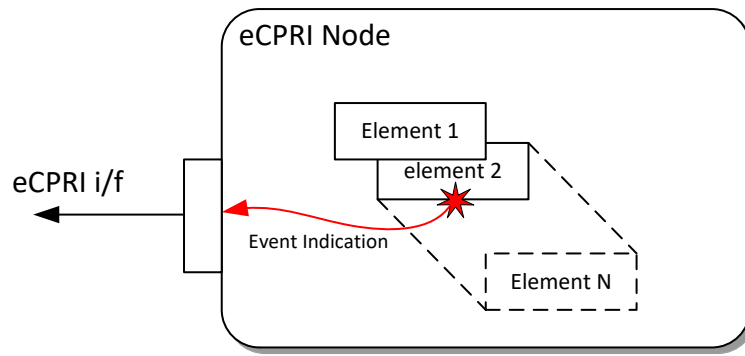

2

3

4

Figure 29: Model for event indications

5 3.2.4.8.2. Message format

6 The Event Indication message format is shown in Figure 30.

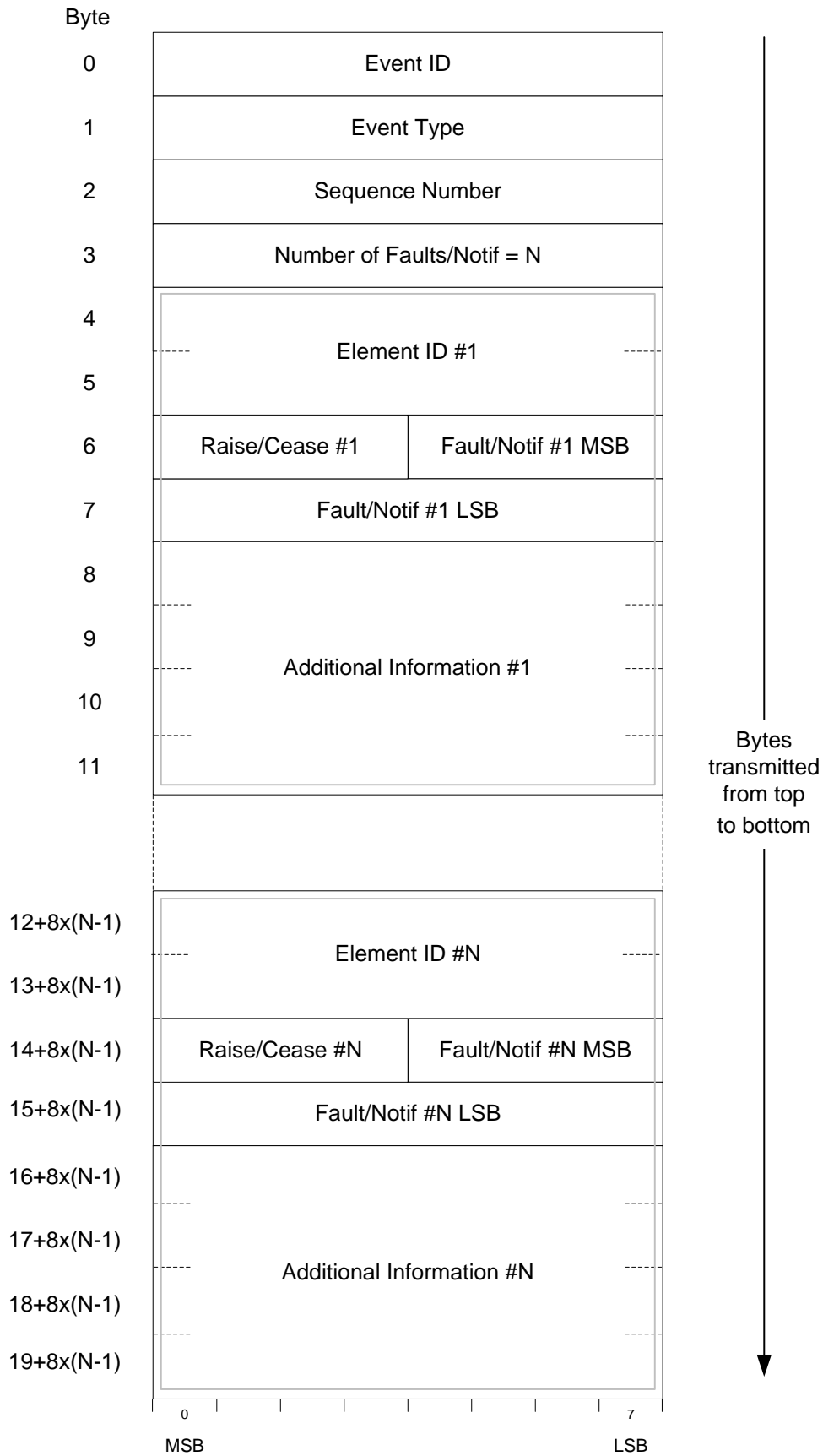

1

2

Figure 30: Event indication message

1 Where:

- 2 • Event ID

3 A 1-byte value set by the transmitter of an Event Indication or a Synchronization Request to enable  
4 identification of the acknowledge response.

- 5 • Event Type

6 Table 10: Event Type

Event Type	Description
0x00	Fault(s) Indication
0x01	Fault(s) Indication Acknowledge
0x02	Notification(s) Indication
0x03	Synchronization Request
0x04	Synchronization Acknowledge
0x05	Synchronization End Indication
0x06...0xFF	Reserved

7

- 8 • Sequence Number

9 The Sequence Number is a 1-byte value that is incremented each time the transmitter sends the “Event  
10 Indication” with Event Type set to 0x00 (Fault(s) Indication). The receiver will use the sequence number  
11 to ensure that the correct status for a specific combination of {Element-ID; Fault-value} is used. Due to  
12 the nature of the packet based fronthaul network, packets might be delivered out of order and a  
13 sequence number is needed to handle this scenario. When a fault indication is not acknowledged the  
14 transmitter will re-transmit the fault, setting the sequence number to the same value used in the initial  
15 transmission.

- 16 • Number of Faults/Notifications

17 Number of fault indications or notifications attached in the same message.

- 18 • Element ID:

19 Table 11: Element ID

Element ID Number	Usage
0x0000 ... 0xFFFFE	Vendor specific usage
0xFFFF	A fault or notification applicable for all Elements i.e. the node

20

- 21 • Raise/cease:

22 First nibble in the same byte as the Fault/Notification Number.

23

Table 12: Raise/ceased

Raise/Cease	Description
0x0	Raise a fault
0x1	Cease a fault
0x2 ... 0xF	Reserved

- 1 • Fault/Notification Numbers:  
2 A 12-bit number indicating a fault or notification divided between 2 bytes.

Table 13: Fault/Notification numbers

Fault Indication and Notification Numbers	Usage
0x000 ... 0x3FF	eCPRI reserved Faults
0x400 ... 0x7FF	eCPRI reserved Notifications
0x800 ... 0xFFFF	Vendor Specific Fault Indications and Notifications
eCPRI Faults and Notifications	
0x000	General Userplane HW Fault
0x001	General Userplane SW Fault
0x002 ... 0x3FF	eCPRI reserved
0x400	Unknown message type received
0x401	Userplane data buffer underflow
0x402	Userplane data buffer overflow
0x403	Userplane data arrived too early
0x404	Userplane data received too late
0x405 ... 0x7FF	eCPRI reserved

- 4 • Additional Information:  
5 If available, additional information regarding the fault/notification for vendor specific usage.

#### 6 3.2.4.8.3. Message sequence diagram

- 7 An eCPRI node can at any time send an Event Indication to the peer node. Depending on what Event Type,  
8 different fields will be set or copied according to Table 14.

Table 14: Parameter handling

Event Type	Event ID	Sequence Number	Nbr of Faults or Notifications	Fault/Notification(s)	Raise/Cease	Additional Information
Fault Indication	Set	Increment	> 0	Fault(s)	Raise or Cease	Vendor Specific
Fault Indication Acknowledge	Copied	Copied	0	Not included	Not included	Not Included
Synchronization Request	Set	Set to 0	0	Not included	Not included	Not Included
Synchronization Acknowledge	Copied	Set to 0	0	Not included	Not included	Not Included
Synchronization End Indication	Copied	Set to 0	0	Not included	Not included	Not Included
Notification	Set	Set to 0	>0	Notifications	Set to 0x0	Vendor specific

10

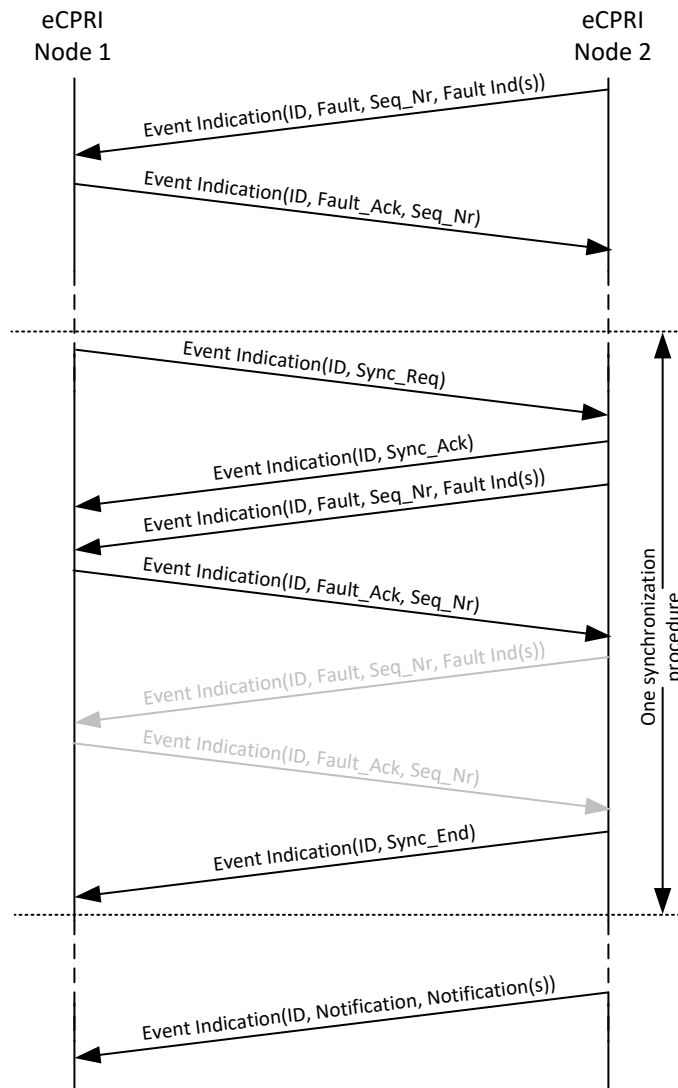

1

2

Figure 31: Message sequence diagram (example)

3 The first part of the sequence above shows when Node 2 detects a fault condition which is signalled to Node  
4 1 and Node 1 acknowledges the reception of the indication.

5 The middle part of the sequence diagram shows a Synchronization procedure. The procedure is started with  
6 a Synchronization-Request sent by Node 1, signals marked in grey might be sent due to number of faults or  
7 due to the implementation. The request is acknowledged by Node 2, Node 2 then sends the current list of  
8 raised faults to Node 1, the sequence is ended when Node 2 sends the Synchronization-End message. In  
9 the Synchronization procedure the 'Event ID' set by Node 1 in the request message will be used during the  
10 full procedure.

11 The last part of the sequence shows when Node 2 sends a notification to Node 1, this notification is not  
12 acknowledged by Node 1.

### 13 3.2.4.9. Message Type #8-#63: Reserved

14 eCPRI message types from 8 to 63 are reserved for future eCPRI specifications.

### 15 3.2.4.10. Message Type #64-#255: Vendor Specific

16 eCPRI message types from 64 to 255 are not defined in eCPRI. These are for vendor specific usage. Vendor  
17 specific message types shall not be reserved (before any specific usage is defined) by any 3<sup>rd</sup> parties (other  
18 than CPRI and vendors).

19 Vendor specific usage shall be guaranteed.



### 1 3.3. C&M Plane

2 Control and management information will be exchanged between eCPRI entities (eREC and eRE) on any  
3 commonly used transport protocols. The C&M information will not be transmitted via the eCPRI specific  
4 protocol. The details of this information flow are out of the scope of the eCPRI specification. This information  
5 can use protocols (e.g. TCP) over the IP protocol but any other solution is not precluded.

6 The C&M information flow will be considered as non-time-critical and utilize a small part of the total  
7 bandwidth between eCPRI entities. The majority of this information flow will be considered as background  
8 traffic, the rest are interactive traffic that is needed to keep control of the eCPRI node. See section 6.6 for  
9 considerations regarding priority for C&M data.

### 10 3.4. Synchronization Plane

11 The eCPRI nodes shall recover the synchronization and timing from a synchronization reference source, and  
12 the air interface of the eRE shall meet the 3GPP synchronization and timing requirements. The  
13 synchronization information will not be transmitted via the eCPRI specific protocol. The details of this  
14 information flow are out of the scope of the eCPRI specification. This information flow can use existing  
15 protocols (e.g. SyncE, PTP) but any other solution is not precluded.

16 The synchronization information flow will be considered as time-critical and will utilize a small part of the total  
17 bandwidth between eCPRI nodes.

### 18 3.5. QoS

19 The quality of service (QoS) control for eCPRI is implemented by setting different priority for different traffic  
20 flows depending of the needed quality of service. If the eCPRI fronthaul network is Ethernet-switched the  
21 priority field (PCP field) in the VLAN-tag shall be used for QoS of eCPRI, see further details below. If the  
22 eCPRI fronthaul network is IP-routed the Differentiated Services (DiffServ) can be used.

#### 23 3.5.1. VLAN Tagging for Ethernet-switched fronthaul networks

24 For an Ethernet network with Ethernet bridges a VLAN tag according to the IEEE 802.1Q-2014 [14] shall  
25 always be added by the eRE or eREC and provided to the Ethernet network. The VLAN ID does not need to  
26 be set if only the priority is used in the VLAN tag. In that case the VLAN ID (VID field) is set to zero (the null  
27 VID). The priority is set in the PCP field of the VLAN tag.

28 Normally a C-tag with a priority in the PCP field is set by the eCPRI nodes (VID is optional), but other cases  
29 may exist depending on the network type and what kind of customer service interface to the network is used.  
30 For further details and options see [14].

31 The use of the VLAN ID (VID field), including the null VID, is fully vendor specific and agreed with the  
32 network provider.

33 How to use the priority field (PCP field) is vendor specific. See section 6.6.

#### 34 3.5.2. QoS for IP-routed fronthaul networks

35 QoS for IP-routed fronthaul network can be done by DiffServ. The DiffServ uses the DSCP field in the  
36 differentiated services field (DS field) in the IP header for classification purposes. How to use the DSCP field  
37 for QoS in an IP-routed fronthaul network is fully vendor specific.

38 Other ways to implement QoS in an IP-routed fronthaul network are possible.

## 1 4. Forward and Backward Compatibility

2 In order to allow for forward and backward compatibility of eCPRI, the following requirements are introduced.

### 3 4.1. Fixing eCPRI Protocol Revision Position

4 For forward and backward compatibility, the eCPRI Protocol Revision field in the common header shall be  
5 fixed in all revisions. This is in order to find the eCPRI protocol revision correctly.

### 6 4.2. Reserved Bits and Value Ranges within eCPRI

7 Within the eCPRI message format some data parts are reserved for future use by the CPRI specification  
8 group. These parts may be used in future releases of the eCPRI specification to enhance the capabilities or  
9 to allow the introduction of new features in a backward compatible way. The reserved data parts are of two  
10 different types:

- 11 1. Reserved bits in the eCPRI common header or reserved bits within a specific message payload.
- 12 2. Reserved value ranges in both eCPRI common header and within a specific message payload.

13 Reserved data parts of type 1: the transmitter shall send 0's for the reserved bits, and the receiver shall not  
14 interpret the reserved bits.

15 Reserved data parts of type 2: the transmitter is only allowed to use values that are defined by this  
16 specification or as defined within a vendor specific range. The receiver shall discard the message when  
17 receiving a message with illegal values.

### 18 4.3. eCPRI specification release version

19 The eCPRI specification release version is indicated by two digits (version A.B). The following text defines  
20 the digits:

- 21 • The first digit A is incremented to reflect significant changes (modification of the scope, new section...).
- 22 • The second digit B is incremented for all changes of substance, i.e. technical enhancements,  
23 corrections, updates etc.

### 24 4.4. Specification release version mapping to eCPRI protocol 25 revision

26 The eCPRI common header field "eCPRI Protocol revision" indicates the protocol version number, which will  
27 be denoted by 1, 2, 3, ... The protocol revision number will be incremented only when a new specification  
28 release version includes changes that lead to incompatibility with previous specification release versions.

29 The simple sequence and the well-defined rule for non-compatibility between different specification release  
30 versions allows for a simple, efficient and fast start-up procedure. The following table provides the mapping  
31 between specification release version and protocol revision number.

32 Table 15: Specification release version and protocol revision numbering

Specification release version	Available eCPRI protocol revision values	Comment
1.0, 1.1, 1.2	0001b	The interpretation of the eCPRI message shall follow eCPRI specification version 1.0.
	0010b-1111b; 0000b	Reserved for future eCPRI protocol revisions. Unallocated values can temporarily be used for vendor specific extensions until allocated.

33

34 This table shall be updated when new specification release versions become available.

---

## 1 5. Compliance

2 An eCPRI compliant interface shall fulfill the following requirements:

- 3
- 4 • An eCPRI compatible interface shall follow the normative parts of this specification.
  - 5 • One or more eCPRI message types are used over the interface for eREC and eRE communication.
  - 6 • eCPRI message types in use are implemented as per their defined requirements.

---

## 1 6. Annex A - Supplementary Specification Details 2 (Informative)

### 3 6.1. Functional Decomposition

#### 4 6.1.1. eCPRI Functional Decomposition

5 The functional content of the PHY layer and a typical processing order is shown in Figure 32. Process stages  
6 marked with grey text are optional, i.e. in a non-massive antenna configuration those stages are not present.  
7 The eCPRI specification focuses on three different reference splits, two splits in downlink and one split in  
8 uplink (Split I<sub>b</sub>, II<sub>b</sub> and I<sub>u</sub>). Any combination of the different downlink/uplink splits is possible.

9 Nevertheless, any other split within the PHY layer (and also any other inter/intra layer split) is not precluded  
10 to be used with the eCPRI specification.

11 The major difference between Split I<sub>b</sub> and II<sub>b</sub> is that the data in Split I<sub>b</sub> is bit oriented and the data in split II<sub>b</sub>  
12 and I<sub>u</sub> is IQ oriented.

13 In Figure 32 only the data plane processing stages are shown, but in parallel to this, a user data real time  
14 control flow also exists. Depending on where the split is, this real-time control data is e.g. modulation  
15 scheme, Tx power, beamforming information etc. The bit rate of this real-time control flow differs between  
16 different splits. As a rule of thumb the closer to the MAC layer the split is, the more real time control data  
17 needs to be sent between the two eCPRI nodes eREC and eRE.

18 It is possible to implement e.g. a PRACH preamble detection process in the eRE and handling of SRS in the  
19 eRE thus lowering the bit rate needs in the uplink direction, these options/possibilities are however not  
20 shown in Figure 32. Also, in the downlink direction the reference signals and synchronization signals could  
21 be generated internally on the eRE with just an initial configuration by the eREC, this is not shown in the  
22 figure either.

23 One of the major objectives of a new functional split between eREC and eRE compared to the classical  
24 CPRI functional split is to lower the bit rates on the fronthaul interface. When looking at the different  
25 processing stages performed in the PHY-layer (see Figure 32) in downlink direction, three processes will  
26 mostly increase the bit rate. These three processes are modulation, the port-expansion being done in  
27 combination with the beamforming process and the IFFT+cyclic-prefix-process (i.e. going from the frequency  
28 domain to the time domain). By moving the split upwards in the figure the fronthaul bit rate will be lowered  
29 and vice versa. But conversely the bit rate for the user plane real-time control data will increase when moving  
30 the split point towards the MAC layer and vice versa.

31

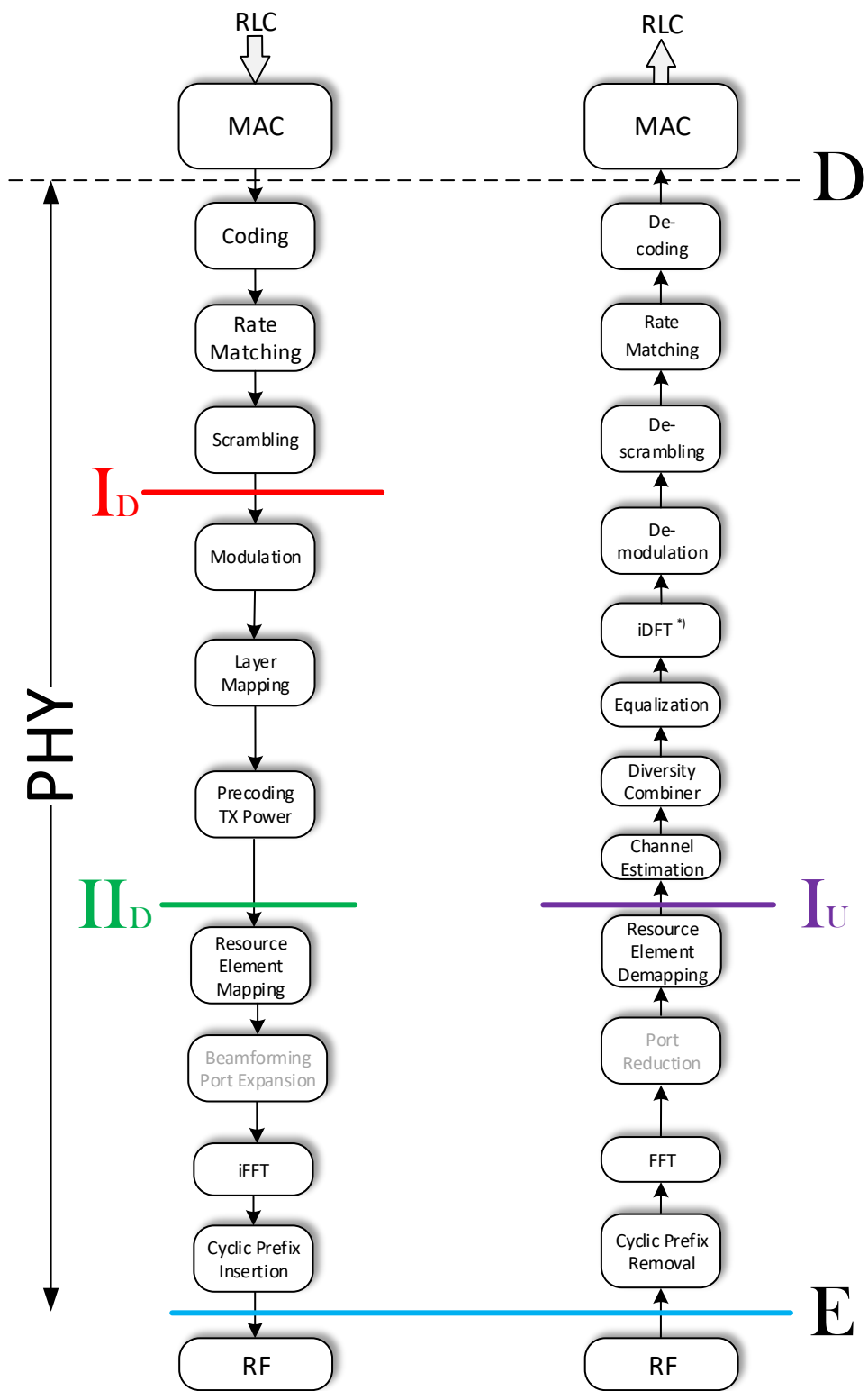

\*) Mandatory processing stage for 4G, optional for 5G according to 3GPP Technical Specification 38.300 section 5.1

1

2

Figure 32: PHY layer and eCPRI splits

## 1 6.1.2. Bit Rate Calculations / Estimations

2 When making the decision for what split to implement one major issue will be the bit rate capacity on the link  
3 between the eREC and the eRE. When moving the split point from the MAC-PHY boundary towards the RF  
4 layer the bit rate will increase for each step. This applies for the user data, the opposite is true for the control  
5 data needed to process the data on the eRE, i.e. the bitrate for the control data will decrease when moving  
6 the split towards the RF layer. However, the sum of the bit rates for the user data and the control data will not  
7 remain the same.

8 It is assumed that the control algorithm for e.g. beamforming resides in the eREC and that control data for  
9 these stages must be transmitted from eREC to eRE.

10 When going to a split that is above the split E there are many factors that will have an impact on the final  
11 needed bit rate of the link between eREC and eRE. The most relevant factors are:

- 12 • Throughput (closely related to the available and used air bandwidth)
- 13 • Number of MIMO-layers
- 14 • MU-MIMO support (y/n)
- 15 • Code rate
- 16 • Modulation scheme
- 17 • Beamforming algorithm
- 18 • Number of antennas

19 When making a comparison of the needed bit rate between an eCPRI split and the classical CPRI split (split  
20 E) one needs to set a specific use case.

21 Among the abovementioned factors, only the "Number of antennas" has an impact on the bit rate for split E.

22 There are on the other hand other factors that have an impact on the needed bit rate for a split E  
23 implementation as well which are not mentioned in the bullet list above. These factors are mainly: sample  
24 frequency for the IQ-data, used IQ-format (number of bits per IQ-sample) and the presence of IQ  
25 compression algorithms or not.

### 26 6.1.2.1. Bit Rate Calculation Example

27 eCPRI has no limitation with respect to the factors mentioned in the previous section.

28 As an example, the following values are used for the forthcoming bit rates calculations:

- 29 • Throughput: 3/1.5 Gbps (downlink/uplink, end-user data rate, transport block from/to MAC)
- 30 • Air bandwidth: 100 MHz (5 \* LTE20) -> 500 PRB
- 31 • Number of downlink MIMO-layers: 8
- 32 • Number of uplink MIMO-layers: 4 (with 2 diversity streams per uplink MIMO layer)
- 33 • MU-MIMO: No
- 34 • TTI length: 1 ms
- 35 • Digital beamforming where BF-coefficients calculation is performed in eREC.
- 36 • Rate matching assumptions: Code rate: ~0.80
- 37 • Modulation scheme (Downlink & Uplink): 256 QAM
- 38 • Number of antennas: 64
- 39 • Sub-carrier spacing: 15 kHz
- 40 • IQ sampling frequency: 122.88 Msps (3.84\*32)
- 41 • IQ-format: 30 bits per IQ-sample
- 42 • No IQ compression

43

Table 16: PHY layer splits bit rate estimations for the example use case above

	Split D		Split I <sub>D</sub>		Split II <sub>D</sub>		Split E
	User Data [Gbps]	Control [Gbps]	User Data [Gbps]	Control [Gbps]	User Data [Gbps]	Control [Gbps]	User Data [Gbps]
eREC → eRE	3 (assumption)	<< 1	< 4	< 10	~ 20	< 10	236
			Split I <sub>U</sub>				
eRE → eREC	1.5 (assumption)	<< 1	~ 20	< 10	~ 20	< 10	236

## 6.2. Synchronization and Timing

An eCPRI node shall recover the frequency and time/phase from its synchronization reference source (see Figure 3). In an eCPRI installation all eCPRI nodes (eRECs and eREs) need to be time synchronized to a common time reference, see sections 6.2.1 and 6.2.2 for more information.

Different solutions exist for synchronization of eREC and eRE.

### 6.2.1. Synchronization of eRE

Depending on which 3GPP features a specific eCPRI installation supports, different timing accuracy requirements are applicable for the eRE node. [15] defines four different timing synchronization requirement categories each one targeting different timing accuracy requirements for different use cases. The different categories will supply different timing accuracy at the edge of the fronthaul network, i.e. “almost” at the input-port on the eRE. With the knowledge of the expected supplied timing accuracy it will be possible to implement an eRE that will fulfill the final timing accuracy requirement on the air interface according to the 3GPP requirements.

The eRE shall also fulfill requirements set by 3GPP on the transmission frequency accuracy and the phase noise (implicit requirement).

### 6.2.2. Synchronization of eREC

The timing accuracy requirement on the eREC is relaxed compared to the requirement set on the eRE (see 6.2.1). Actually, the eREC does not need to have a high quality frequency available since it is the eRE that will generate the frequency for air transmission locally. Nevertheless, there will be a vendor specific requirement set on the eREC regarding the eREC timing accuracy. Such a requirement is needed to be able to send data at correct time to the eRE from the eREC thus to give the eRE time for its processing of the data before being transmitted on the air interface and for buffer handling due to network latency variation. The requirement value depends on vendor specific choices related to desired performance for the wireless network, expected delay variation in fronthaul network etc.

## 6.3. Link Delay Management

The following section provides a description of the link delay management in eCPRI. Figure 33 shows an example of an eREC and eRE connected via an eCPRI network. Both eREC and eRE clocks are synchronized to a common grand master clock (in this example via PTP).

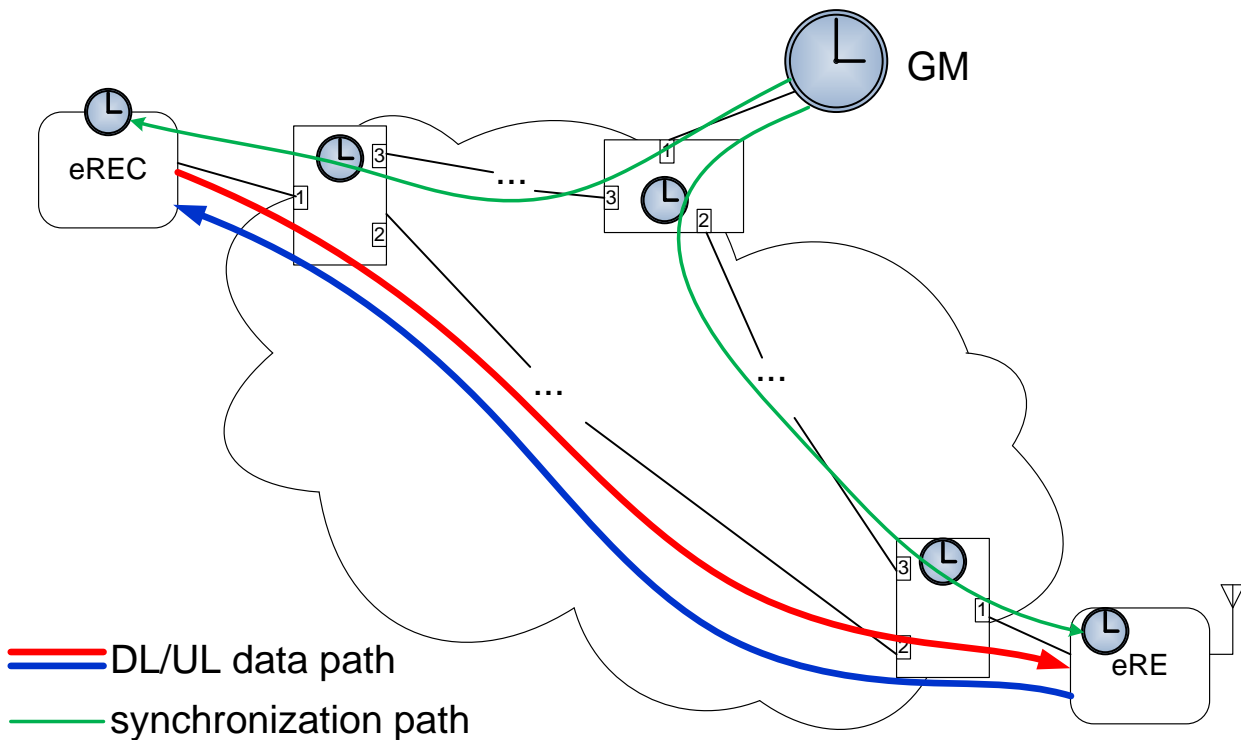

1

2

Figure 33: eCPRI topology example with synchronization via PTP

### 6.3.1. Reference Points for Delay Measurement

The reference points for delay management are the input and the output points of the equipment, i.e. the connectors of eREC and eRE as shown in Figure 34.

Reference points R1 to R4 correspond to the output point (R1) and the input point (R4) of the eREC, and the input point (R2), and the output point (R3) of an eRE. The antenna is shown as “Ra” for reference.

8

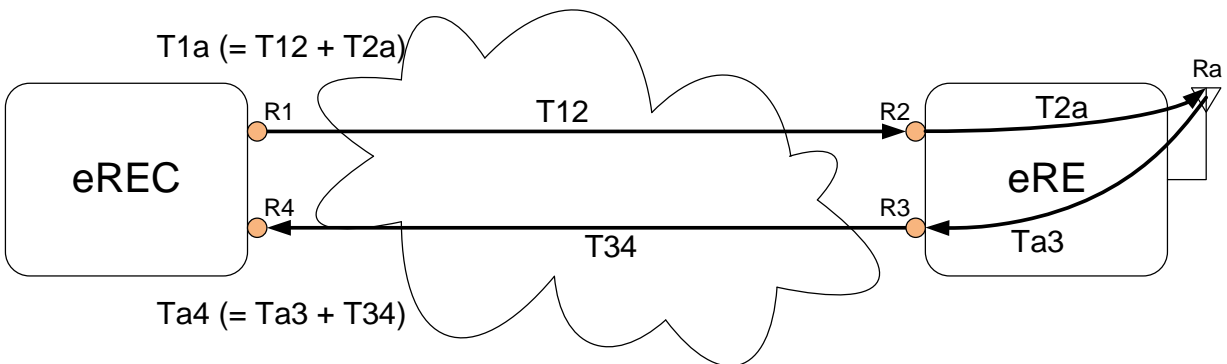

9

Figure 34: Definition of reference points for delay management

The definitions for the different delays are given in the remaining of this section.

Note: The eRE delay definitions refer to the delay between the transmission/reception of an IQ sample at the antenna Ra and the reception/transmission of data packets containing the corresponding information at the fronthaul interface R1/R4 (eREC) and R2/R3 (eRE). In case of time domain IQ functional split, the assignment is straight forward since an eCPRI message carries IQ samples. In case of frequency domain functional split, the information associated to an IQ sample is contained in a set of N packets, e. g. frequency domain IQ data for one OFDM symbol + related control information or user data for one OFDM symbol + related control information.

18



1 Please note that N can vary per symbol/TTI according to the number of users/used resource blocks.

- 2 • T12 is the transport network delay of a user data packet between eREC (R1) and eRE (R2) in DL  
3 direction. T12 may not be constant for every data packet and shows a statistical variation, but its range  
4 is limited by e.g. the profile of deployed transport network:

$$5 \quad 0 \leq T12 \text{ min} \leq T12 \leq T12 \text{ max}$$

6 Where:

- 7 ○ T12 max is given as the maximum one way end-to-end latency, see e.g. [15].  
8 ○ T12 min is 0 in general, but in case the minimum latency of some or all network elements are  
9 known, it can be determined by the sum of all fiber delays and minimum forwarding delays of  
10 the network nodes along the DL data path.

- 11 • T34 is the transport network delay of a user data packet between eRE (R3) and eREC (R4) in UL  
12 direction. T34 may not be constant for every data packet and shows a statistical variation, but its range  
13 is limited by e.g. the profile of deployed transport network:

$$14 \quad 0 \leq T34 \text{ min} \leq T34 \leq T34 \text{ max}$$

15 Where:

- 16 ○ T34 max is given as the maximum one way end-to-end latency, see e.g. [15].  
17 ○ T34 min is 0 in general, but in case the minimum latency of some or all network elements are  
18 known, it can be determined by the sum of all fiber delays and minimum forwarding delays of  
19 the network nodes along the UL data path.

- 20 • T1a is the timing difference between the transmission of a user data packet at the output point R1 of  
21 the eREC and the transmission of IQ samples at the antenna Ra of the eRE. The transmission of the  
22 earliest IQ sample which is generated from the transmitted user data is used as the reference timing at  
23 the antenna Ra. T1a may not be constant but its range is limited by e.g. eREC design specification:

$$24 \quad 0 \leq T1a \text{ min} \leq T1a \leq T1a \text{ max}$$

25 Where:

- 26 ○ Both T1a min and T1a max are vendor specific values; in general, T1a min is related to the best  
27 case processing time of user data and T1a max is related to the worst case processing time and  
28 the output buffer size.

- 29 • T2a is the timing difference between the reception of a user data packet at the input point R2 of eRE  
30 and the transmission of IQ samples at the antenna Ra. The transmission of the earliest IQ sample  
31 which is generated from the received user data is used as the reference timing at the antenna Ra. T2a  
32 may not be constant but its range is limited by e.g. eRE design specification:

$$33 \quad 0 \leq T2a \text{ min} \leq T2a \leq T2a \text{ max}$$

34 Where:

- 35 ○ Both T2a min and T2a max are vendor specific values; in general, T2a min is related to the  
36 worst case eRE processing time of user data and T2a max is related to the input buffer size and  
37 the worst case eRE processing time.

- 38 ○ If a user data packet arrives outside of this reception window (i.e. earlier than T2a max or later  
39 than T2a min), the user data packet may not be used and consequently IQ samples related to  
40 this user data packet may not be generated correctly.

- 41 • Ta3 is the timing difference between the reception of IQ samples at the antenna Ra and the  
42 transmission of a user data packet at the output point R3 of eRE. The reception timing of the earliest  
43 IQ sample necessary to generate the user data packet is used as the reference timing at the antenna  
44 Ra. Ta3 may not be constant but its range is limited by e.g. eRE design specification:

$$45 \quad 0 \leq Ta3 \text{ min} \leq Ta3 \leq Ta3 \text{ max}$$

1 Where:

2 ○ Both Ta3 min and Ta3 max are vendor specific values; in general, Ta3 min is related to the best  
3 case eRE processing time of user data and Ta3 max is related to the worst case eRE  
4 processing time and the output buffer size.

5 • Ta4 is the timing difference between the reception of IQ samples at the antenna Ra of the eRE and  
6 the reception of a user data packet at the input point R4 of the eREC. The reception timing of the  
7 earliest IQ sample necessary to generate the user data packet is used as the reference timing at the  
8 antenna Ra. Ta4 may not be constant but its range is limited by e.g. eRE design specification:

$$9 \quad 0 \leq Ta4 \text{ min} \leq Ta4 \leq Ta4 \text{ max}$$

10 Where:

11 ○ Both Ta4 min and Ta4 max are vendor specific values; in general, Ta4 min is related to the  
12 input buffer size and the worst case eREC processing time. Ta4 max is related to the eREC  
13 worst case processing time of user data.

14 ○ If a user data packet arrives outside of this reception window (i.e. earlier than Ta4 min or later  
15 than Ta4 max), the user data packet may not be used and (a part of) the UL user data may be  
16 lost or degraded.

17 The DL timing relations are shown in Figure 35. eREC and eRE clocks are synchronized to a common GM  
18 and it is assumed that both eREC and eRE know the timing relation between air frame start and their clocks.  
19 The time point when the first IQ sample of a DL air frame has to be transmitted at the antenna is indicated by  
20 the red line on the right.

21 By definition, the following equation has to be satisfied:

$$22 \quad T1a = T12 + T2a$$

23 This equation implies that fluctuation of transport network latency and the eREC transmission timing has to  
24 be absorbed by the input buffer of eRE; moreover the minimum/maximum limits of these three variables are  
25 not independent; i.e. the following conditions have to be met in order not to lose DL user data.

$$26 \quad T1a \text{ min} \geq T12 \text{ max} + T2a \text{ min}$$

$$27 \quad T1a \text{ max} \leq T12 \text{ min} + T2a \text{ max}$$

$$28 \quad \text{“Tx window size at R1”} \leq \text{“Rx window size at R2”} - \text{“max fluctuation of transport network latency”}$$

29 Where:

$$30 \quad \text{“Tx window size at R1”} = T1a \text{ max} - T1a \text{ min}$$

$$31 \quad \text{“Rx window size at R2”} = T2a \text{ max} - T2a \text{ min}$$

$$32 \quad \text{“Max fluctuation of transport network latency”} = T12 \text{ max} - T12 \text{ min}$$

33

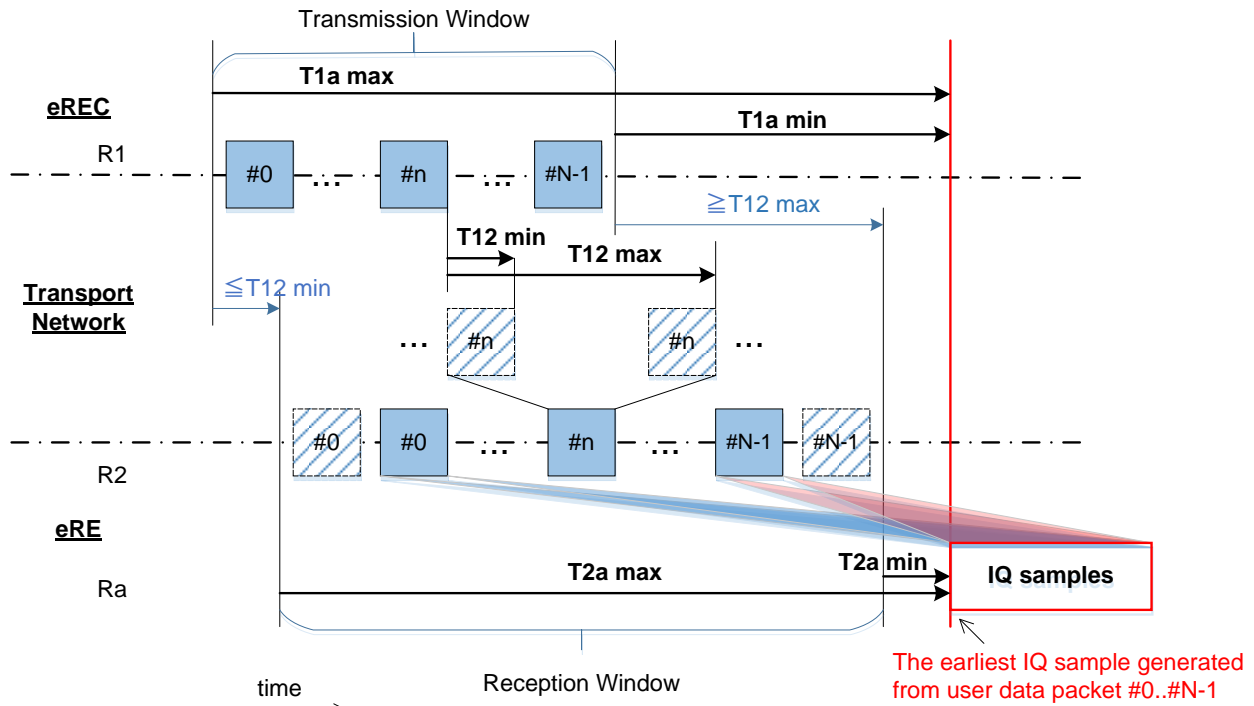

1  
2  
3  
4  
5  
6  
7  
8  
9  
10  
11  
12  
13  
14  
15  
16  
17

Figure 35: Timing relations in DL direction

The UL timing relations are shown in Figure 36. The time point when the first IQ sample of a UL air frame to be received at the antenna is indicated by the red line on the left.

By definition, the following equation has to be satisfied:

$$Ta_4 = Ta_3 + T_{34}$$

Therefore the minimum/maximum limits of these three variables are not independent; i.e. the following conditions have to be met in order not to lose UL user data.

$$Ta_4 \text{ min} \leq Ta_3 \text{ min} + T_{34} \text{ min}$$

$$Ta_4 \text{ max} \geq Ta_3 \text{ max} + T_{34} \text{ max}$$

$$\text{"Rx window size at R4"} \geq \text{"Tx window size at R3"} + \text{"max fluctuation of transport network latency"}$$

Where:

$$\text{"Tx window size at R3"} = Ta_3 \text{ max} - Ta_3 \text{ min}$$

$$\text{"Rx window size at R4"} = Ta_4 \text{ max} - Ta_4 \text{ min}$$

$$\text{"Max fluctuation of transport network latency"} = T_{34} \text{ max} - T_{34} \text{ min}$$

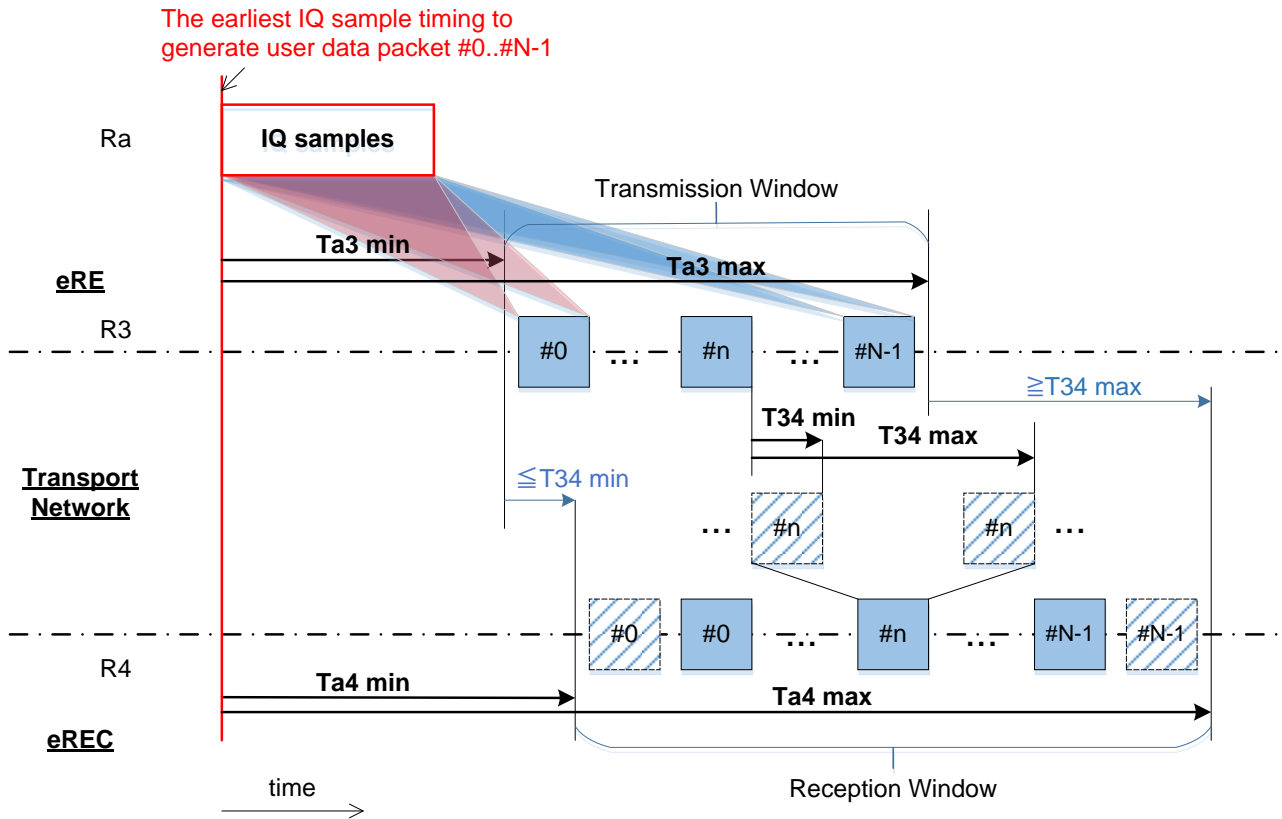

Figure 36: Timing relations in UL direction

### 6.3.2. Delay Management example

Figure 37 shows a model of UL/DL eCPRI user data transmission between eCPRI nodes (eREC and eRE). Both transmitter and receiver side of eCPRI nodes have buffer memories to absorb the fluctuation of transport network delay as well as the variation of processing time in eCPRI nodes which depends on the traffic and processing load. The goal of delay management is to avoid the overflow/underflow of buffer memories and to decrease the overall delay, the necessary size of buffer memories, etc. at the same time. Additionally a sort of traffic shaping may be necessary at the transmitter side to avoid unnecessary traffic congestion. Flow control with fast feedback loop is not considered in this example.

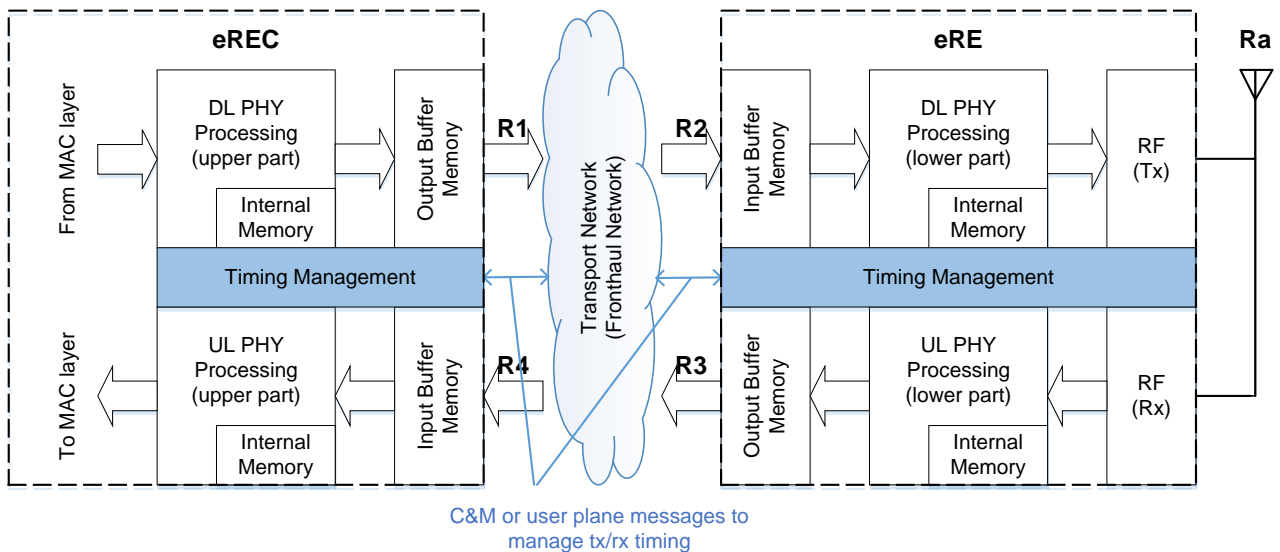

Figure 37: Delay management model example

1

2 eREC functions:

- 3 • Measure the actual typical/maximum/minimum one-way delay between the eREC and the eRE (UL and
- 4 DL direction) in addition to the nominal maximum/minimum transport network delay and allocate the
- 5 optimum delay budget to the eREC, the eRE and the transport network.
- 6 ○ eCPRI service “one-way E2E delay measurement” is used.
- 7 ○ Measure the delay periodically if necessary.
- 8 • Manage the transmission timing of UL/DL user plane messages in order to ensure that messages arrive
- 9 at the eRE properly (i.e. within the reception windows at the eRE), considering:
  - 10 ○ UL/DL frame timing at the antenna of the eRE (strictly defined by 3GPP specification)
  - 11 ○ Deadline of each user plane message (or a group of messages) for the eRE to start/complete
  - 12 UL/DL processing to avoid buffer underflow.
  - 13 ○ The maximum size of the input buffer at the eRE as well as the remaining size to avoid buffer
  - 14 overflow.
  - 15 ○ The actual delay of the transport network and processing time in the eRE based on reports from
  - 16 the eRE.
- 17 • Declare the allowable reception window timing for each (or a group of) UL user plane message(s)
- 18 relative to the air interface frame timing.
  - 19 ○ The end of the window (deadline) depends on the processing time in the eREC (vendor specific),
  - 20 especially the HARQ related processing.
  - 21 ○ The beginning of the window depends on the input buffer size in the eREC (vendor specific)
- 22 • Monitor the actual reception timing of (critical) user plane message and the input buffer status, and
- 23 request the eRE to adapt the transmission timing if necessary.

24 eRE functions:

- 25 • Manage the transmission timing of UL user plane messages in order to ensure that messages arrive at
- 26 the eREC properly (i.e. within the reception windows at the eREC).
- 27 • Declare the allowable reception window timing for each (or a group of) UL/DL user plane message(s)
- 28 relative to the air interface frame timing.
  - 29 ○ The end of the window (deadline) depends on the processing time in the eRE (vendor specific).
  - 30 ○ The beginning of the window depends on the input buffer size in the eRE (vendor specific).
- 31 • Monitor the actual reception timing of (critical) user plane messages and the input buffer status, and
- 32 report them to the eREC.
  - 33 ○ At least, the occurrence of buffer overflow/underflow (late delivery) should be reported.
  - 34 ○ Reports may be transferred by C&M plane or eCPRI services (“Real-Time Control Data” or “Event
  - 35 Indication”) depending on its time criticality.
- 36 • Additionally, traffic shaping of UL user data may be necessary to avoid unnecessary transport network
- 37 congestion, especially in case the transport network bandwidth is shared by multiple synchronized TDD
- 38 eREs.

39 Figure 38 shows an example of DL user data transmission timing between the eREC and the eRE.

40 In this example, we assume:

- 41 • The eREC transmits user data each OFDM symbol interval (e.g. 67usec for LTE).
- 42 • The eRE has an input buffer large enough to store full messages for 3 OFDM symbols.
- 43 • Only worst cases (regarding min/max delay of transport network, maximum processing time in the eRE)
- 44 are considered.

- 1 • The transmission timing of the first IQ sample of OFDM symbol #n at the eRE antenna Ra is used as
- 2 the reference timing. This timing is strictly defined by 3GPP specification, so fluctuation is not allowed.
- 3 • The eREC transmits all user data packets which are necessary to generate OFDM symbol #n within the
- 4 transmission window [T1a max, T1a min] before its first IQ sample is transmitted from the eRE antenna.
- 5 • The eRE receives all user data packets which are necessary to generate OFDM symbol #n within the
- 6 reception window [T2a max, T2a min] before its first IQ sample is transmitted from the eRE antenna.

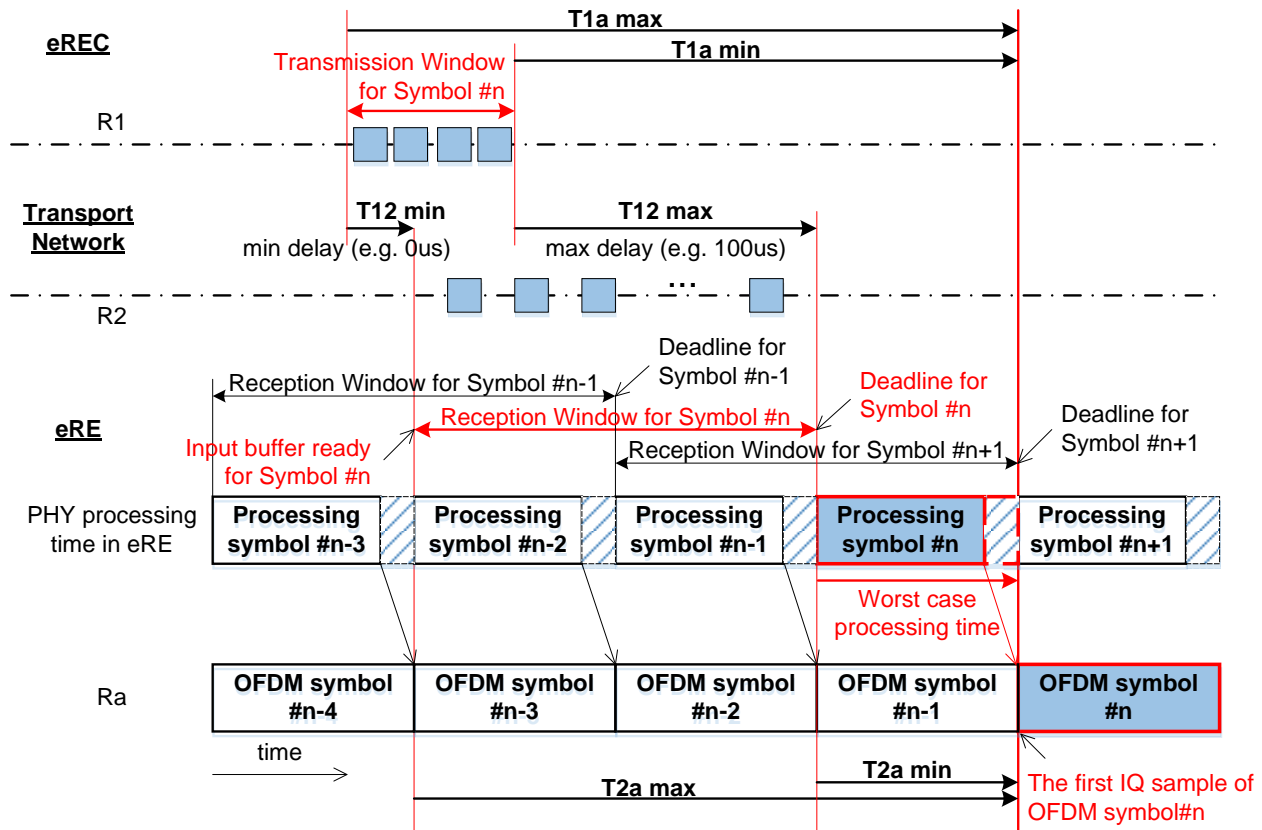

Figure 38: DL user data transmission timing example

## 6.4. Network Connection Maintenance

Network connection maintenance and network connection control is out of scope of the eCPRI specification. There are a number of different methods and standards that can be used.

For the Ethernet parts of eCPRI (if applicable for the User plane data and for IP over Ethernet), the Ethernet OAM can be used. Ethernet OAM is a common name for the IEEE 802.1Q [14] and ITU-T Recommendation G.8013/Y.1731 [16]. The IEEE 802.1Q Ethernet CFM (Connectivity Fault Management) defines three protocols, Continuity Check Protocol (CC), Link Trace (LT) and Loop-back (LB). ITU-T defines the same functions and tools in Y.1731 by the Ethernet continuity check (ETH-CC), Ethernet remote defect indication (ETH-RDI), Ethernet link trace (ETH-LT) and Ethernet loopback (ETH-LB), and also adds more OAM functions like Ethernet alarm indication signal (ETH-AIS), Ethernet loss measurement (ETH-LM) or synthetic loss measurement (ETH-SLM), and Ethernet delay measurement (ETH-DM).

For the IP parts of the eCPRI (e.g. the C&M flow), the Internet Control Message Protocol (ICMP) can be used. ICMP for IPv4 is defined in RFC 792 [17] and for IPv6 it is defined in RFC 4443 [18].

An eCPRI node needs to have either a unique MAC address or a unique IP address. How to assign or get these addresses is out of scope of the eCPRI specification.

## 1 6.5. Networking

### 2 6.5.1. Difference between eCPRI and CPRI

3 This subsection describes the major differences between eCPRI and CPRI (e.g. CPRI v7.0). The main  
4 audience of this section is anyone familiar with CPRI and who would like to understand the difference  
5 between eCPRI and CPRI networking quickly. So it may not be of any use to new readers of eCPRI who are  
6 not interested in CPRI.

7 Figure 39 shows an example network by CPRI. CPRI has the following characteristics:

- 8 • CPRI is a point-to-point interface by nature.
- 9 • There is a master-port and a slave-port connected directly by optical/electrical cable(s) (a hop).
- 10 • Networking functions are application layer functions and not supported by the CPRI interface itself.
- 11 • Supported topologies depend on REC/RE functions.
- 12 • Supported logical connections include:
  - 13 ○ Point-to-point (one REC – one RE).
  - 14 ○ Point-to-multi-point (one REC – several REs).
- 15 • Redundancy, QoS, security, etc. are REC/RE functions (if required).

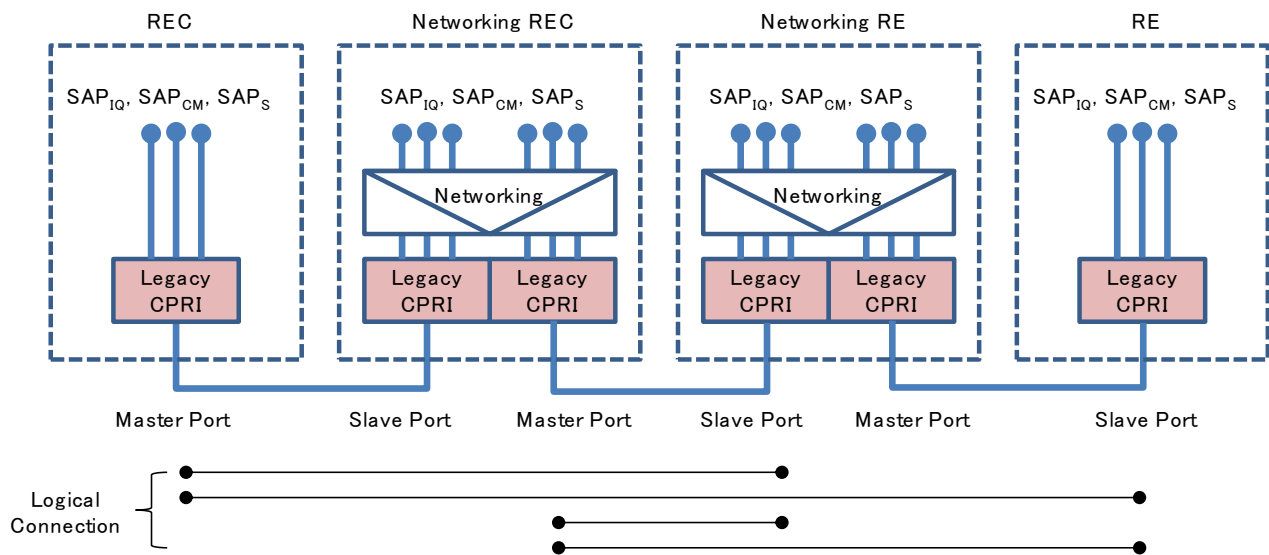

17  
18 Figure 39: Network by legacy CPRI

19 Figure 40 shows an example network by eCPRI. eCPRI has the following characteristics:

- 20 • An eCPRI network consists of eCPRI nodes (eRECs and eREs), transport network, as well as other  
21 network elements not shown in Figure 40 (including GM/BC for timing, EMS/NMS for management).
- 22 • There is no longer a master port/slave port classification at physical level.
  - 23 ○ SAP<sub>S</sub>: master of PTP and Synchronous Ethernet is not a eREC in general.
  - 24 ○ SAP<sub>CM</sub>: some of M-plane may be managed by EMS/NMS.
- 25 • The eCPRI layer is above the transport networking layer.
- 26 • The eCPRI layer does not care about the actual transport network layer topology.
- 27 • The transport network may include some local network, e.g. local switch(es) provided by the eREC/eRE  
28 vendors.

- 1 • Supported logical connections include:
- 2 ○ Point-to-point (one eREC – one eRE), same as legacy CPRI.
- 3 ○ Point-to-multi-point (one eREC – several eREs), same as legacy CPRI
- 4 ○ Multi-point-to-multi-point (eRECs – eREs, eRECs – eRECs, eREs - eREs), new for eCPRI but not
- 5 always necessary.
- 6 • Redundancy, QoS, security, etc. are mainly transport network functions; eCPRI nodes need to
- 7 implement proper transport network layer protocols to support these capabilities if required.
- 8

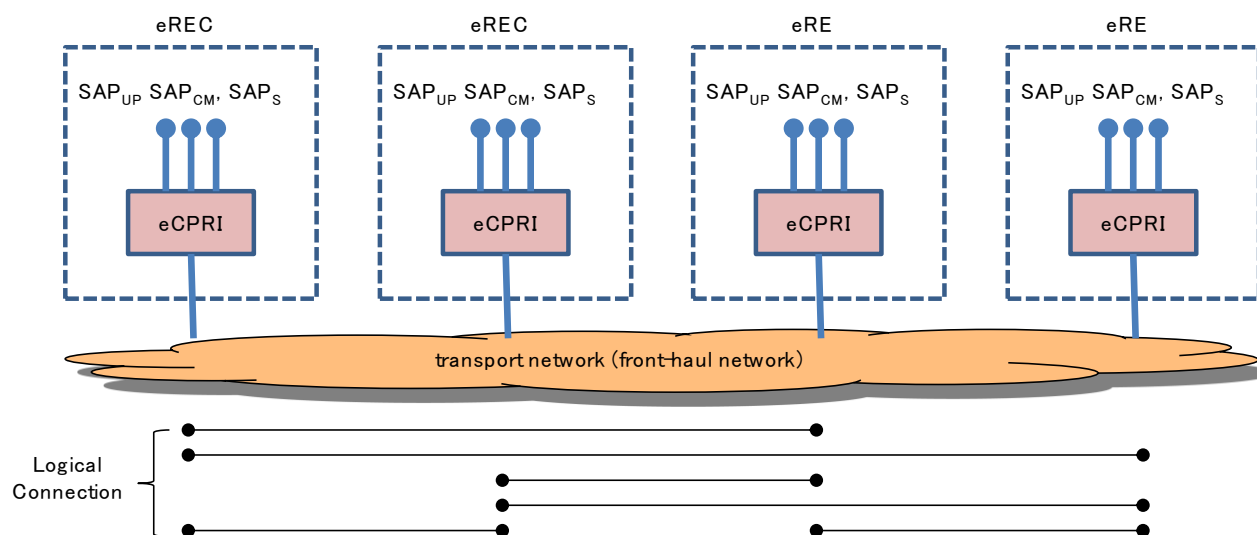

9

10 Figure 40: Network by eCPRI

## 11 6.6. Priority considerations

12 The User data and Real-Time Control data are the most time sensitive flows and normally require a high

13 priority. The traffic on the User Plane can in many cases be split into different kinds of traffic with different

14 need of QoS. In that case it might be good to have several priorities for the User Plane Data.

15 The C&M data flow is normally not time sensitive and can be set to a low priority. But it may be wise to have

16 two different priorities for C&M. One with lower priority than the User Plane Data that can be used for C&M

17 considered as background traffic, and one with higher priority than the User Plane Data for the interactive

18 traffic. The interactive traffic (including critical operation and emergency) needs to come through even if the

19 amount of User Plane Data exceeds the available network bandwidth.

20 Note that for an Ethernet-switched fronthaul network there are only up to eight priorities available and in a

21 provider network other traffic might need at least one priority. So even if there are many traffic streams with

22 different QoS needs (e.g. for the User Plane Data) it will be good to keep down the total number of QoS

23 levels.

## 24 6.7. Message Ordering Considerations

25 The eCPRI transport network may not guarantee preservation of the eCPRI messages order (i.e. the order in

26 which a sequence of eCPRI messages is transmitted by the source node may be different from the order in

27 which the sequence is received at the destination node). Order preservation may not be guaranteed even

28 assuming the same priority, type of message, source node and destination node.

29 This is partially addressed by the inclusion of a sequence related ID field for some of the eCPRI message

30 types.



## 1 6.8. Security

2 This section covers security considerations related to eCPRI traffic. If the transport network is not safe for a  
3 particular flow then an eCPRI network end-to-end security system should be implemented in the eREC node  
4 and eRE node for that flow.

### 5 6.8.1. eCPRI Network Security Protocol

6 eCPRI Network Security Protocol suites include IPsec in IP traffic and MACsec in Ethernet traffic, IPsec and  
7 MACsec are designed to provide interoperable, high quality, cryptography-based security for IP and Ethernet  
8 traffic. The set of security services offered includes access control, connectionless integrity, data origin  
9 authentication, protection against replays (a form of partial sequence integrity), confidentiality (encryption),  
10 and limited traffic flow confidentiality. These services are provided at the IP or Ethernet layer, offering  
11 protection for Ethernet or IP and/or upper layer protocols.

12 The details of IPsec and MACsec usage is vendor specific.

### 13 6.8.2. eCPRI Network Security Specification

14 Vendors can choose e.g. IPsec or MACsec to ensure security of transmission.

#### 15 6.8.2.1. User plane

16 User plane over IP:

- 17 • IPsec or MACsec are both optional solutions to provide transmission security.

18 User plane over Ethernet:

- 19 • MACsec is an optional solution to provide transmission security.

#### 20 6.8.2.2. C&M plane

21 TLS, IPsec or MACsec are optional solutions to provide transmission security and access control for eCPRI  
22 C&M plane.

#### 23 6.8.2.3. Synchronization plane

24 There is no eCPRI recommendation for security aspects related to the synchronization plane.

---

## 1 7. List of Abbreviations

2	3GPP	3rd Generation Partnership Project
3	BC	Boundary Clock
4	C&M	Control and Management
5	CFM	Connectivity Fault Management
6	CoMP	Coordinated Multipoint
7	CCP	Continuity Check Protocol
8	CFP	C Form-factor Pluggable
9	CPRI	Common Public Radio Interface
10	DiffServ	Differentiated Services
11	DL	Downlink
12	DSCP	Differentiated Services Code Point
13	EMS	Element Management System
14	eNB	Evolved NodeB
15	eRE	eCPRI Radio Equipment
16	eREC	eCPRI Radio Equipment Control
17	ETH-CC	Ethernet Continuity Check
18	ETH-AIS	Ethernet Alarm Indication Signal
19	ETH-LT	Ethernet Link Trace
20	ETH-LB	Ethernet Loopback
21	ETH-RDI	Ethernet Remote Defect Indication
22	ETH-LM	Ethernet Loss Measurement
23	E-UTRA	Evolved Universal Terrestrial Radio Access
24	FFT	Fast Fourier Transform
25	GM	Grandmaster
26	gNB	5G base station name
27	GPS	Global Positioning System
28	HW	Hardware
29	ICMP	Internet Control Message Protocol
30	iDFT	inverse Discrete Fourier Transformation
31	IEEE	Institute of Electrical and Electronics Engineers
32	IFFT	Inverse Fast Fourier Transform
33	IP	Internet Protocol
34	IPsec	Internet Protocol Security
35	IQ	In-phase and Quadrature
36	L1	Layer 1
37	LT	Link Trace
38	LLC	Logical Link Control
39	LB	Loop-Back
40	LSB	Least Significant Bit

1	LTE	Long Term Evolution
2	MAC	Media Access Control
3	MACsec	Media Access Control Security
4	MIMO	Multiple Input, Multiple Output
5	MSB	Most Significant Bit
6	Msp/s	Mega sample per second
7	MU-MIMO	Multi-User MIMO
8	NMS	Network Management System
9	NR	New Radio Access Technology (for 5G)
10	OAM	Operations, Administration and Maintenance
11	OFDM	Orthogonal Frequency-Division Multiplexing
12	PCP	Priority Code Point
13	PDCP	Packet Data Convergence Protocol
14	PDU	Protocol Data Unit
15	PHY	Physical Layer
16	PRACH	Physical Random Access Channel
17	PTP	Precision Time Protocol
18	QoS	Quality of Service
19	QSFP	Quad Small Form-factor Pluggable
20	RE	Radio Equipment
21	REC	Radio Equipment Control
22	Req	Request
23	Resp	Response
24	RF	Radio Frequency, Radio Functions
25	RLC	Radio Link Control
26	RRC	Radio Resource Control
27	Rx	Receive
28	SAP	Service Access Point
29	SCTP	Stream Control Transmission Protocol
30	SFP	Small Form-factor Pluggable
31	SNMP	Simple Network Management Protocol
32	SRS	Sounding Reference Signal
33	SW	Software
34	$t_1$	Timestamp 1
35	$t_2$	Timestamp 2
36	TCP	Transmission Control Protocol
37	$t_{cv1}$	Compensation Value 1
38	$t_{cv2}$	Compensation Value 2
39	$t_D$	One-Way Delay
40	TLS	Transport Layer Security
41	TTI	Transmission Time Interval

1	Tx	Transmit
2	UDP	User Datagram Protocol
3	UE	User Equipment
4	UL	Uplink
5	UMTS	Universal Mobile Telecommunication System
6	VID	VLAN Identifier
7	VLAN	Virtual LAN

---

## 8. References

- 1 [1] Common Public Radio Interface (CPRI) Interface Specification V7.0
- 2 [2] [http://www.3gpp.org/ftp/Specs/archive/36\\_series/](http://www.3gpp.org/ftp/Specs/archive/36_series/)
- 3 [3] [http://www.3gpp.org/ftp/Specs/archive/38\\_series/](http://www.3gpp.org/ftp/Specs/archive/38_series/)
- 4 [4] ITU-T Rec. G.8275.1/Y.1369.1 (06/2016) Precision time protocol telecom profile for phase/time
- 5 synchronization with full timing support from the network
- 6
- 7 [5] IEEE Std 802.3™-2015 IEEE, New York, USA, 3rd December 2015.
- 8 [6] IEEE Std 802.3by™-2016 IEEE, New York, USA, 30th June 2016.
- 9 [7] SFF-8083, SFP+ 1X 10 Gb/s Pluggable Transceiver Solution (SFP10), Rev 3.1, September 13, 2014
- 10 [8] SFF-8402, SFP+ 1X 28 Gb/s Pluggable Transceiver Solution (SFP28), Rev 1.1 September 13, 2014
- 11 [9] SFF-8635, QSFP+ 4X 10 Gb/s Pluggable Transceiver Solution (QSFP10), Rev 0.6 June 29, 2015
- 12 [10] SFF-8665, QSFP+ 28 Gb/s 4X Pluggable Transceiver Solution (QSFP28), Rev 1.9 June 29, 2015
- 13 [11] <http://standards-oui.ieee.org/ethertype/eth.txt>
- 14 [12] ISO/IEC 10646:2014, Information technology - Universal Coded Character Set (UCS)
- 15 [13] IEEE Std 1588™-2008 (Revision of IEEE Std 1588-2002), New York, USA, 24 July 2008
- 16 [14] IEEE Std 802.1Q™-2014 (Revision of IEEE Std 802.1Q-2011), New York, USA, 3 November 2014
- 17 [15] Requirements for the eCPRI Transport Network ([www.cpri.info](http://www.cpri.info))
- 18 [16] ITU-T Recommendation G.8013/Y.1731 - Operation, administration and maintenance (OAM) functions
- 19 and mechanisms for Ethernet-based networks, 08/2015
- 20 [17] RFC 792 - INTERNET CONTROL MESSAGE PROTOCOL, September 1981
- 21 [18] RFC 4443 - Internet Control Message Protocol (ICMPv6), for the Internet Protocol Version 6 (IPv6)
- 22 Specification, March 2006
- 23 [19] IEEE Std 802.3cc™-2017 IEEE, New York, USA, 6th December 2017.

## 1 9. History

Version	Date	Description
V 1.0	2017-08-22	First eCPRI specification
V 1.1	2018-01-10	Editorial corrections
V 1.2	2018-06-25	<p>Section 1:</p> <ul style="list-style-type: none"> <li>• “The eCPRI interface can also be used between two eREC units or between two eRE units” added below figure 1</li> </ul> <p>Section 2.3:</p> <ul style="list-style-type: none"> <li>• Table 1: Reference to 38.133 added for RF functions in NR case</li> </ul> <p>Section 3.1.1:</p> <ul style="list-style-type: none"> <li>• Table 3: 25GBase LR/ER added with reference [19]</li> </ul> <p>Section 3.2.4.7.1:</p> <ul style="list-style-type: none"> <li>• “shall” replaced by “should”: “Upon reception of a valid “Reset request”, the eRE <i>should</i> send a “Remote Reset” Indication before performing the requested reset.”</li> </ul> <p>Section 6.1.1:</p> <ul style="list-style-type: none"> <li>• Figure 32 updated (legend added for iDFT UL processing block)</li> <li>• Footnote 4 removed</li> </ul> <p>Section 6.1.2:</p> <ul style="list-style-type: none"> <li>• Reworked and new subsection 6.1.2.1 “Bit Rate Calculation Example” introduced</li> </ul> <p>Section 8:</p> <ul style="list-style-type: none"> <li>• New reference [19] added</li> </ul>

2