

## Amplifier Classes

Amplifiers are classified into classes according to their construction and operating characteristics

Not all amplifiers are the same and there is a clear distinction made between the way their output stages are configured and operate. The main operating characteristics of an ideal amplifier are linearity, signal gain, efficiency and power output but in real world amplifiers there is always a trade off between these different characteristics.

Generally, large signal or power amplifiers are used in the output stages of audio amplifier systems to drive a loudspeaker load. A typical loudspeaker has an impedance of between 4Ω and 8Ω, thus a power amplifier must be able to supply the high peak currents required to drive the low impedance speaker.

One method used to distinguish the electrical characteristics of different types of amplifiers is by “class”, and as such amplifiers are classified according to their circuit configuration and method of operation. Then **Amplifier Classes** is the term used to differentiate between the different amplifier types.

*Amplifier Classes* represent the amount of the output signal which varies within the amplifier circuit over one cycle of operation when excited by a sinusoidal input signal. The classification of amplifiers range from entirely linear operation (for use in high-fidelity signal amplification) with very low efficiency, to entirely non-

linear (where a faithful signal reproduction is not so important) operation but with a much higher efficiency, while others are a compromise between the two.

Amplifier classes are mainly lumped into two basic groups. The first are the classically controlled conduction angle amplifiers forming the more common amplifier classes of A, B, AB and C, which are defined by the length of their conduction state over some portion of the output waveform, such that the output stage transistor operation lies somewhere between being “fully-ON” and “fully-OFF”.

The second set of amplifiers are the newer so-called “switching” amplifier classes of D, E, F, G, S, T etc, which use digital circuits and pulse width modulation (PWM) to constantly switch the signal between “fully-ON” and “fully-OFF” driving the output hard into the transistors saturation and cut-off regions.

The most commonly constructed amplifier classes are those that are used as audio amplifiers, mainly class A, B, AB and C and to keep things simple, it is these types of **amplifier classes** we will look at here in more detail.

## Class A Amplifier

**Class A Amplifiers** are the most common type of amplifier topology as they use just one output switching transistor (Bipolar, FET, IGBT, etc) within their amplifier design. This single output transistor is biased around the Q-point within the middle of its load line and so is never driven into its cut-off or saturation regions thus allowing it to conduct current over the full 360 degrees of the input cycle. Then the output transistor of a class-A topology never turns “OFF” which is one of its main disadvantages.

Class “A” amplifiers are considered the best class of amplifier design due mainly to their excellent linearity, high gain and low signal distortion levels when designed correctly. Although seldom used in high power amplifier applications due to thermal power supply considerations, class-A amplifiers are probably the best sounding of all the amplifier classes mentioned here and as such are used in high-fidelity audio amplifier designs.

## Class A Amplifier

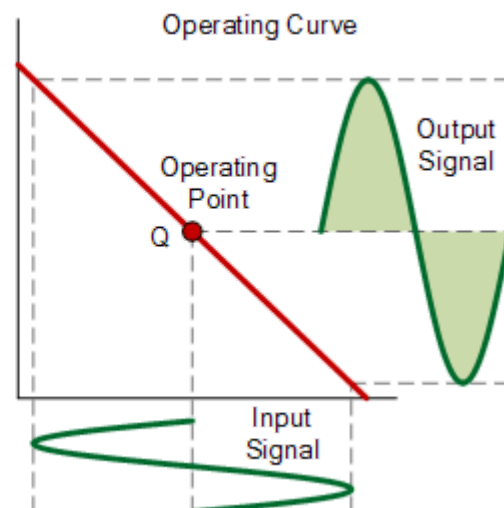
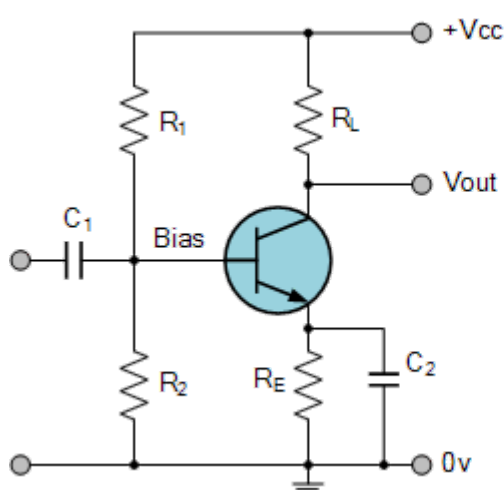

To achieve high linearity and gain, the output stage of a class A amplifier is biased “ON” (conducting) all the time. Then for an amplifier to be classified as “Class A” the zero signal idle current in the output stage must be equal to or greater than the maximum load current (usually a loudspeaker) required to produce the largest output signal.

As a class A amplifier operates in the linear portion of its characteristic curves, the single output device conducts through a full 360 degrees of the output waveform. Then the class A amplifier is equivalent to a current source.

Since a class A amplifier operates in the linear region, the transistors base (or gate) DC biasing voltage should be chosen properly to ensure correct operation and low distortion. However, as the output device is “ON” at all times, it is constantly carrying current, which represents a continuous loss of power in the amplifier.

Due to this continuous loss of power class A amplifiers create tremendous amounts of heat adding to their very low efficiency at around 30%, making them impractical for high-power amplifications. Also due to the high idling current of the amplifier, the power supply must be sized accordingly and be well filtered to avoid any amplifier hum and noise. Therefore, due to the low efficiency and over heating problems of Class A amplifiers, more efficient amplifier classes have been developed.

## Class B Amplifier

**Class B amplifiers** were invented as a solution to the efficiency and heating problems associated with the previous class A amplifier. The basic class B amplifier uses two complimentary transistors either bipolar or FET for each half of the waveform with its output stage configured in a “push-pull” type arrangement, so that each transistor device amplifies only half of the output waveform.

In the class B amplifier, there is no DC base bias current as its quiescent current is zero, so that the dc power is small and therefore its efficiency is much higher than that of the class A amplifier. However, the price paid for the improvement in the efficiency is in the linearity of the switching device.

## Class B Amplifier

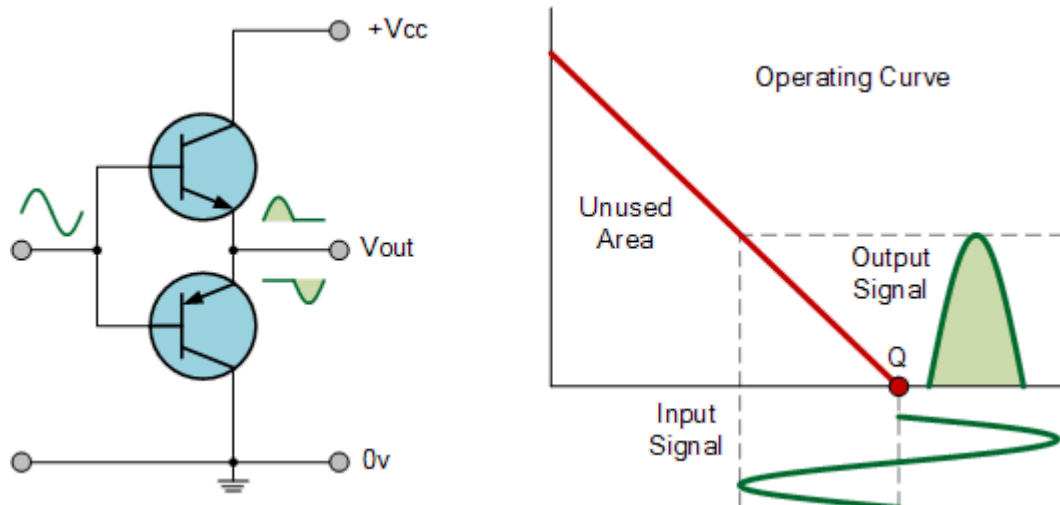

When the input signal goes positive, the positive biased transistor conducts while the negative transistor is switched “OFF”. Likewise, when the input signal goes negative, the positive transistor switches “OFF” while the negative biased transistor turns “ON” and conducts the negative portion of the signal. Thus the transistor

conducts only half of the time, either on positive or negative half cycle of the input signal.

Then we can see that each transistor device of the class B amplifier only conducts through one half or 180 degrees of the output waveform in strict time alternation, but as the output stage has devices for both halves of the signal waveform the two halves are combined together to produce the full linear output waveform.

This push-pull design of amplifier is obviously more efficient than Class A, at about 50%, but the problem with the class B amplifier design is that it can create distortion at the zero-crossing point of the waveform due to the transistors dead band of input base voltages from -0.7V to +0.7.

We remember from the **Transistor** tutorial that it takes a base-emitter voltage of about 0.7 volts to get a bipolar transistor to start conducting. Then in a class B amplifier, the output transistor is not “biased” to an “ON” state of operation until this voltage is exceeded.

This means that the the part of the waveform which falls within this 0.7 volt window will not be reproduced accurately making the class B amplifier unsuitable for precision audio amplifier applications.

To overcome this zero-crossing distortion (also known as Crossover Distortion) class AB amplifiers were developed.

## **Class AB Amplifier**

As its name suggests, the **Class AB Amplifier** is a combination of the “Class A” and the “Class B” type amplifiers we have looked at above. The AB classification of amplifier is currently one of the most common used types of audio power amplifier design. The class AB amplifier is a variation of a class B amplifier as described above, except that both devices are allowed to conduct at the same time around the waveforms crossover point eliminating the crossover distortion problems of the previous class B amplifier.

The two transistors have a very small bias voltage, typically at 5 to 10% of the quiescent current to bias the transistors just above its cut-off point. Then the conducting device, either bipolar or FET, will be “ON” for more than one half cycle, but much less than one full cycle of the input signal. Therefore, in a class AB amplifier design each of the push-pull transistors is conducting for slightly more than the half cycle of conduction in class B, but much less than the full cycle of conduction of class A.

In other words, the conduction angle of a class AB amplifier is somewhere between  $180^\circ$  and  $360^\circ$  depending upon the chosen bias point as shown.

## **Class AB Amplifier**

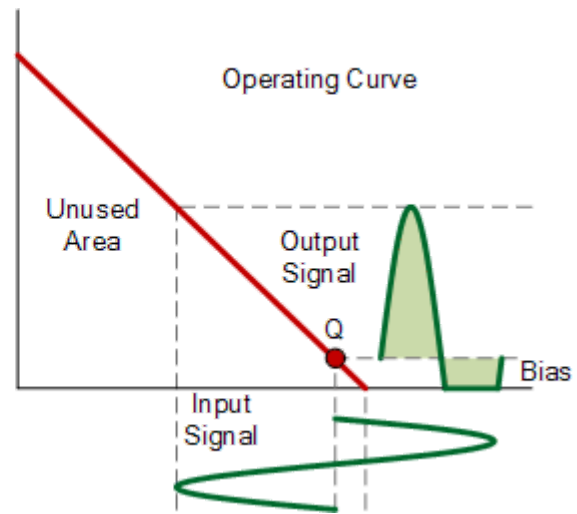
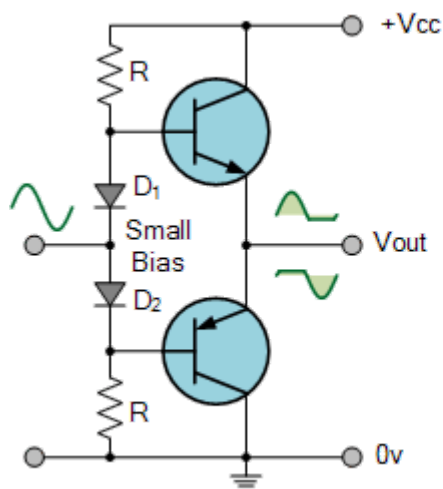

The advantage of this small bias voltage, provided by series diodes or resistors, is that the crossover distortion created by the class B amplifier characteristics is overcome, without the inefficiencies of the class A amplifier design. So the class AB amplifier is a good compromise between class A and class B in terms of efficiency and linearity, with conversion efficiencies reaching about 50% to 60%.

## Class C Amplifier

The **Class C Amplifier** design has the greatest efficiency but the poorest linearity of the classes of amplifiers mentioned here. The previous classes, A, B and AB are considered linear amplifiers, as the output signals amplitude and phase are linearly related to the input signals amplitude and phase.

However, the class C amplifier is heavily biased so that the output current is zero for more than one half of an input sinusoidal signal cycle with the transistor idling at its cut-off point. In other words, the conduction angle for the transistor is significantly less than 180 degrees, and is generally around the 90 degrees area.

While this form of transistor biasing gives a much improved efficiency of around 80% to the amplifier, it introduces a very heavy distortion of the output signal. Therefore, class C amplifiers are not suitable for use as audio amplifiers.

## Class C Amplifier

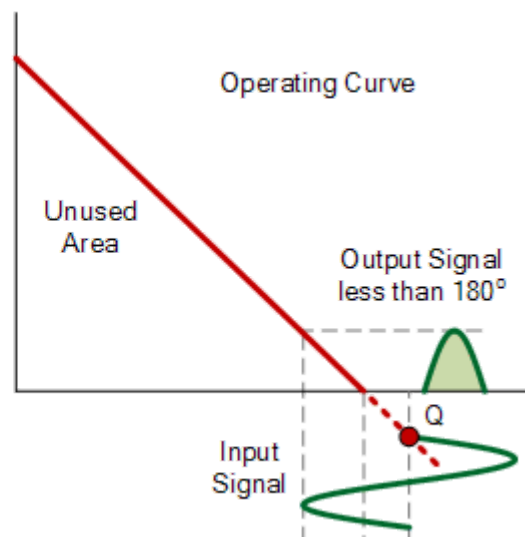
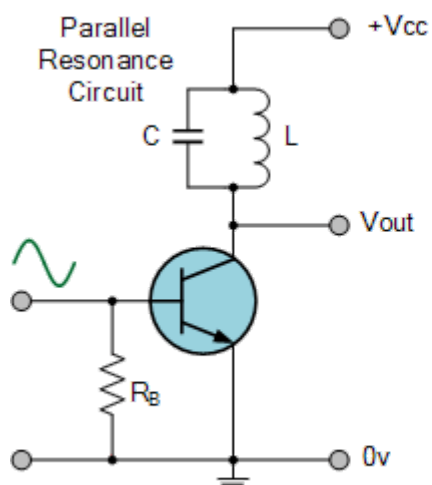

Due to its heavy audio distortion, class C amplifiers are commonly used in high frequency sine wave oscillators and certain types of radio frequency amplifiers, where the pulses of current produced at the amplifiers output can be converted to complete sine waves of a particular frequency by the use of LC resonant circuits in its collector circuit.

## Amplifier Classes Summary

Then we have seen that the quiescent DC operating point (Q-point) of an amplifier determines the amplifier classification. By setting the position of the Q-point at half way on the load line of the amplifiers characteristics curve, the amplifier will operate as a class A amplifier. By moving the Q-point lower down the load line changes the amplifier into a class AB, B or C amplifier.

Then the class of operation of the amplifier with regards to its DC operating point can be given as:

## Amplifier Classes and Efficiency

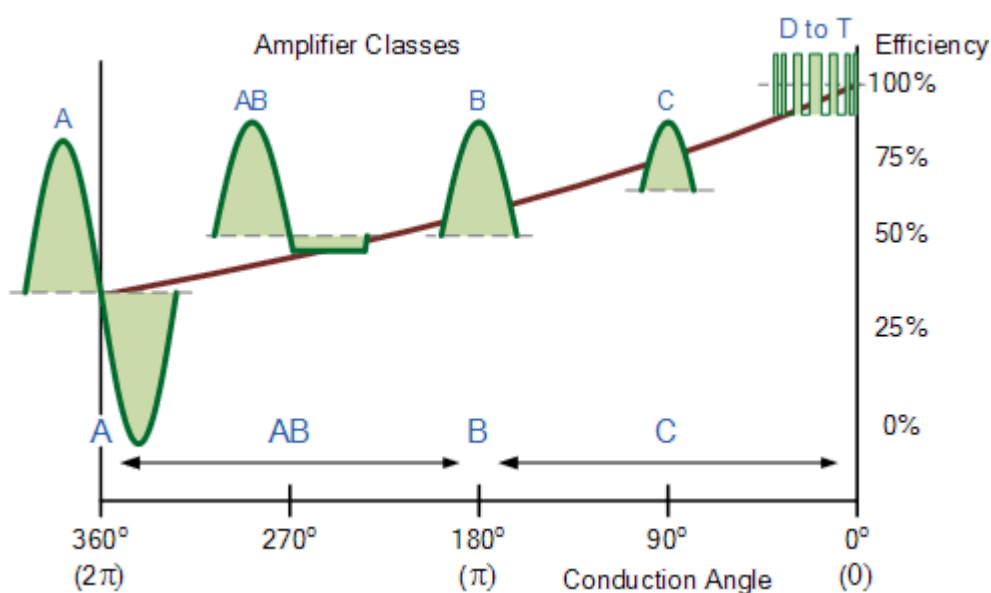

As well as audio amplifiers there are a number of high efficiency **Amplifier Classes** relating to switching amplifier designs that use different switching techniques to reduce power loss and increase efficiency. Some amplifier class designs listed below use RLC resonators or multiple power-supply voltages to reduce power loss, or are digital DSP (digital signal processing) type amplifiers which use pulse width modulation (PWM) switching techniques.

## Other Common Amplifier Classes

- **Class D Amplifier** – A Class D audio amplifier is basically a non-linear switching amplifier or PWM amplifier. Class-D amplifiers theoretically can reach 100% efficiency, as there is no period during a cycle where the voltage and current waveforms overlap as current is drawn only through the transistor that is on.

- **Class F Amplifier** – Class-F amplifiers boost both efficiency and output by using harmonic resonators in the output network to shape the output waveform into a square wave. Class-F amplifiers are capable of high efficiencies of more than 90% if infinite harmonic tuning is used.
- **Class G Amplifier** – Class G offers enhancements to the basic class AB amplifier design. Class G uses multiple power supply rails of various voltages and automatically switches between these supply rails as the input signal changes. This constant switching reduces the average power consumption, and therefore power loss caused by wasted heat.
- **Class I Amplifier** – The class I amplifier has two sets of complementary output switching devices arranged in a parallel push-pull configuration with both sets of switching devices sampling the same input waveform. One device switches the positive half of the waveform, while the other switches the negative half similar to a class B amplifier. With no input signal applied, or when a signal reaches the zero crossing point, the switching devices are both turned ON and OFF simultaneously with a 50% PWM duty cycle cancelling out any high frequency signals.

To produce the positive half of the output signal, the output of the positive switching device is increased in duty cycle while the negative switching device is decreased by the same and vice versa. The two switching signal currents are said to be interleaved at the output, giving the class I amplifier the named of: “interleaved PWM amplifier” operating at switching frequencies in excess of 250kHz.

- **Class S Amplifier** – A class S power amplifier is a non-linear switching mode amplifier similar in operation to the class D amplifier. The class S amplifier converts analogue input signals into digital square wave pulses by a delta-sigma modulator, and amplifies them to increase the output power before finally being demodulated by a band pass filter. As the digital signal of this switching amplifier is always either fully “ON” or “OFF” (theoretically zero power dissipation), efficiencies reaching 100% are possible.
- **Class T Amplifier** – The class T amplifier is another type of digital switching amplifier design. Class T amplifiers are starting to become more popular these days as an audio amplifier design due to the existence of digital signal processing (DSP) chips and multi-channel surround sound amplifiers as it converts analogue signals into digital pulse width modulated (PWM) signals for amplification increasing the amplifiers efficiency. Class T amplifier designs combine both the low distortion signal levels of class AB amplifier and the power efficiency of a class D amplifier.

We have seen here a number of classification of amplifiers ranging from linear power amplifiers to non-linear switching amplifiers, and have seen how an amplifier class differs along the amplifiers load line. The class AB, B and C amplifiers can be defined in terms of the conduction angle,  $\theta$  as follows:

## Amplifier Class by Conduction Angle

Amplifier Class	Description	Conduction Angle
-----------------	-------------	------------------

Class-A	Full cycle 360° of Conduction	$\theta = 2\pi$
Class-B	Half cycle 180° of Conduction	$\theta = \pi$
Class-AB	Slightly more than 180° of conduction	$\pi < \theta < 2\pi$
Class-C	Slightly less than 180° of conduction	$\theta < \pi$
Class-D to T	ON-OFF non-linear switching	$\theta = 0$

## 123 Comments

---

Join the conversation

Write your comment here

Notify me of follow-up comments by email.

SUBMIT